

THE BATTERY CHARGER OF RON PUGH

THANKS IS DUE TO RON PUGH WHO HAS KINDLY SHARED THE CONSTRUCTION DETAILS OF HIS VERY SUCCESSFUL BATTERY CHARGER WHICH IS COP=13 WHEN OPERATING AT 24 VOLTS.

IF YOU DECIDE TO BUILD ONE OF THESE DEVICES THEN PLEASE UNDERSTAND CLEARLY THAT YOU DO SO AT YOUR OWN RISK AND YOU, AND ONLY YOU, ARE RESPONSIBLE FOR YOUR ACTIONS. THIS PRESENTATION IS FOR INFORMATION PURPOSES ONLY.

RON'S DEVICE IS MUCH MORE POWERFUL THAN THE AVERAGE BATTERY CHARGER IN THAT IT HAS FIFTEEN COILS AND PERFORMS MOST IMPRESSIVELY. HERE IS A PHOTOGRAPH OF IT ROTATING AT HIGH SPEED - THE MAGNETS EMBEDDED IN THE ROTOR CAN'T BE SEEN AS THEY ARE PASSING BY TOO FAST FOR THAT :

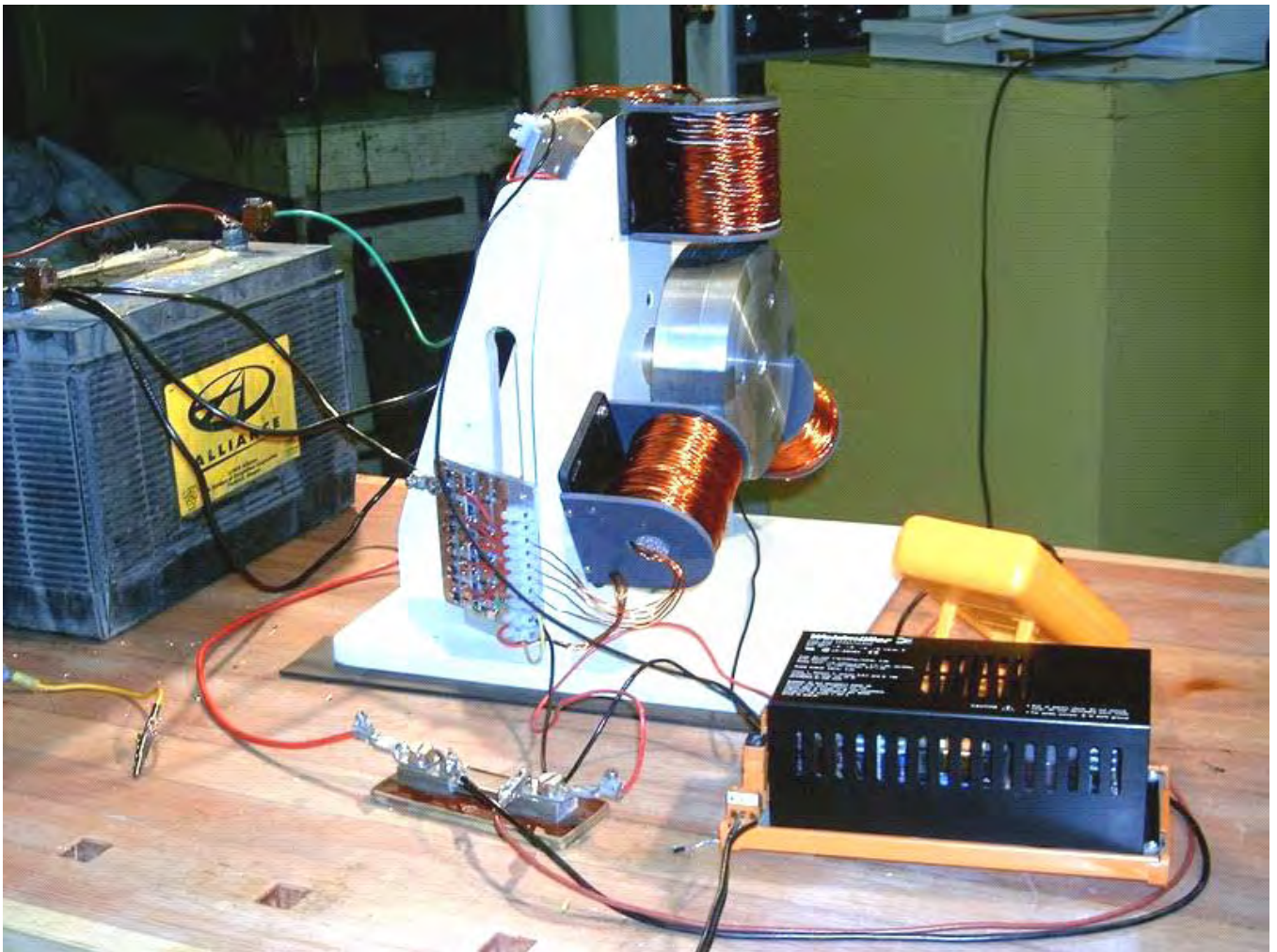

THIS IS NOT A TOY. IT DRAWS SIGNIFICANT CURRENT AND PRODUCES SUBSTANTIAL CHARGING RATES. HERE IS HOW RON CHOSE TO BUILD HIS DEVICE. INTERESTINGLY, CONSIDERING THE MAJOR MAGNETIC EFFECT THAT ALUMINIUM HAS, THE ROTOR IS CONSTRUCTED OF ALUMINIUM WHICH RON'S EXPERIENCE INDICATES IS A VERY SUITABLE MATERIAL FOR THE ROTOR.

THE ROTOR HAS SIX MAGNETS INSERTED IN IT. THESE MAGNETS ARE SPACED SIXTY DEGREES APART WITH THE NORTH POLES FACING OUTWARDS. THE MAGNETS ARE CERAMIC 47 x 22 x 10mm IN SIZE AND THEY ARE USED IN PAIRS SO THERE IS A TOTAL OF TWELVE MAGNETS IN THE CONSTRUCTION.

THE MAGNETS ARE PAIRED TOGETHER TO MATCH THEIR MAGNETIC STRENGTHS AS CLOSELY AS POSSIBLE. HAVING BOUGHT SEVERAL SPARE MAGNETS, RON GRADED THEM ALL IN ORDER OF THEIR MAGNETIC STRENGTH WHICH VARIES A BIT FROM MAGNET TO MAGNET. RON DID HIS GRADING USING A GAUSS METER BUT AN ALTERNATIVE METHOD IS TO USE A PAPER CLIP OF ABOUT 30mm IN LENGTH AND MEASURE THE DISTANCE AT WHICH ONE END OF THE PAPER CLIP JUST STARTS TO RISE OFF THE TABLE AS THE MAGNET IS MOVED TOWARDS IT :

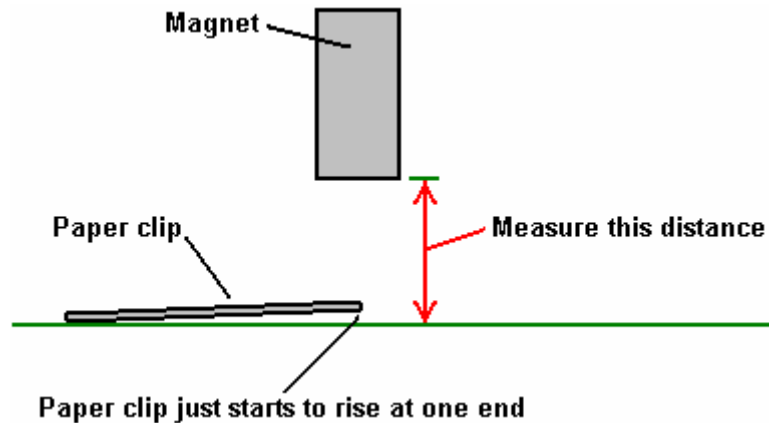

HAVING GRADED THE MAGNETS IN ORDER OF STRENGTH, RON THEN TOOK THE TWELVE STRONGEST MAGNETS AND PAIRED THEM OFF PLACING THE WEAKEST AND STRONGEST TOGETHER, THE SECOND WEAKEST WITH THE SECOND STRONGEST, AND SO ON. THIS PRODUCED SIX PAIRS OF MAGNETS WITH FAIRLY CLOSELY MATCHING MAGNETIC STRENGTHS. THE PAIRS OF MAGNETS WERE THEN GLUED IN PLACE IN THE ROTOR USING SUPER GLUE :

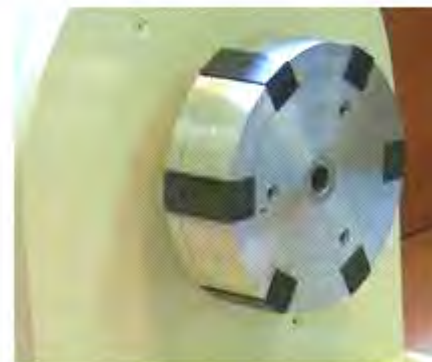
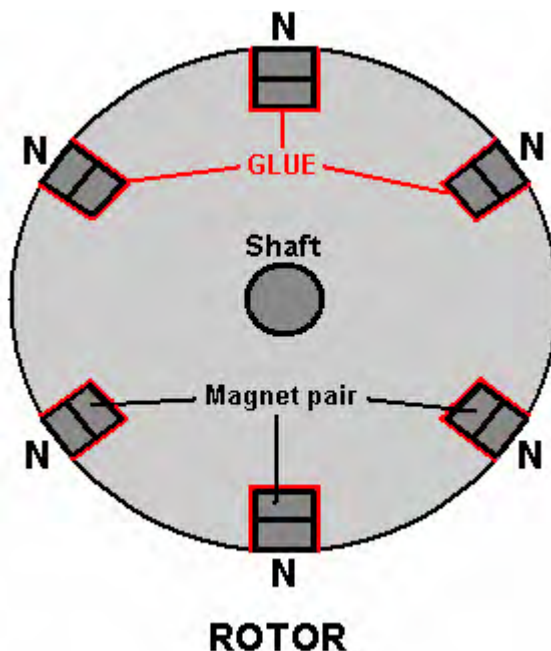

THE CLEARANCE BETWEEN THE MAGNET FACES AND THE COILS IS ABOUT 6mm WHEN THEY ARE ADJUSTED FOR OPTIMUM PERFORMANCE BY SLIDING THE COILS NEARER TO OR FURTHER AWAY FROM THE ROTOR.

THE COILS ARE UNUSUAL IN THAT THEY HAVE FIVE SEPARATE STRANDS OF WIRE IN EACH COIL SPOOL. THE STRANDS OF WIRE ARE TWISTED TOGETHER BEFORE THE COIL IS

WOUND, EFFECTIVELY MAKING EACH COIL SPOOL A FIVE-COIL COMBINATION OF ELECTROMAGNET, TRANSFORMER AND PICK-UP COILS. THERE ARE THREE OF THESE COIL SPOOLS EACH BEING ABOUT 75mm LONG AND WOUND WITH FIVE STRANDS OF #19 AWG OR 20 SWG WIRE (0.912mm DIAMETER). THE COIL SPOOLS WERE MADE FROM PLASTIC PIPE OF 7/8 INCH (22mm) OUTER DIAMETER WHICH RON DRILLED OUT TO AN INNER DIAMETER OF 3/4 INCH (19mm) WHICH GIVES A WALL THICKNESS OF 1.5mm. THE END PIECES FOR THE COIL SPOOLS WERE MADE FROM 3mm THICK PVC WHICH WAS FIXED TO THE PLASTIC TUBE USING PLUMBER'S PVC GLUE.

BEFORE WINDING THE COILS, THE FIVE WIRES WERE TWISTED TOGETHER BY CLAMPING THE ENDS OF THE WIRES TOGETHER TO FORM A 120-FOOT LONG BUNDLE OF WIRES WHICH WAS STRETCHED OUT AND KEPT CLEAR OF THE GROUND BY PASSING IT THROUGH THE OPENINGS IN A SET OF PATIO CHAIRS.

A BATTERY POWERED DRILL WAS ATTACHED TO ONE END AND OPERATED UNTIL THE WIRES WERE LOOSELY TWISTED TOGETHER. THIS TENDS TO TWIST THE WIRES TOGETHER MORE TIGHTLY AT THE END, LEAVING THE SET OF WIRES LOOSER IN THE MIDDLE. SO THE PROCEDURE WAS REPEATED, TWISTING THE OTHER END OF THE BUNDLE (THE DRILL TURNS IN THE SAME DIRECTION FOR THIS). THE TWISTED WIRES ARE COLLECTED ON A LARGE DIAMETER DRUM AND THEN USED TO WIND ONE OF THE COIL SETS FOR THE CHARGER.

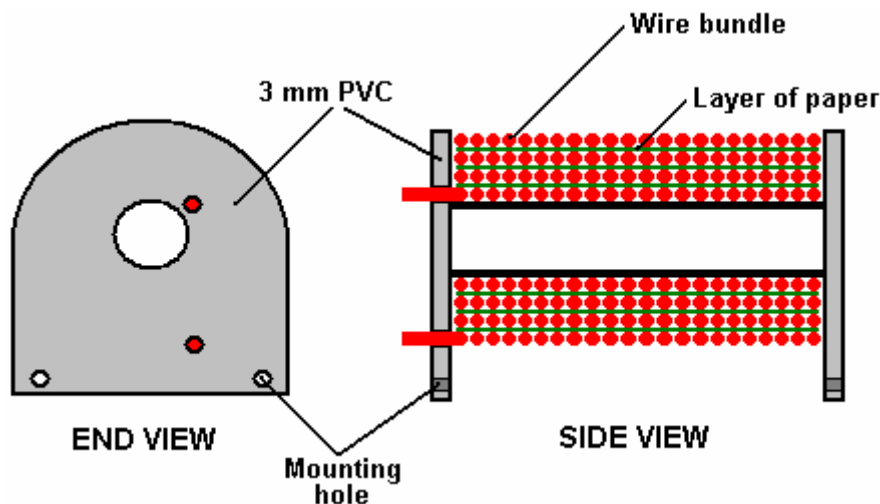

THE COILS ARE WOUND WITH THE END PLATES ATTACHED AND DRILLED READY TO SCREW TO THEIR 6mm PVC BASES WHICH IN TURN ARE BOLTED TO THE 18mm THICK MDF SUPPORTING STRUCTURE. IT IS EASY TO WIND A COIL WITH WIRE THIS THICK AND AT THE END OF EACH FULL LAYER OF WINDING, A LAYER OF PAPER IS ATTACHED AND THAT MAKES THE NEXT LAYER EVEN EASIER TO WIND.

RON'S CONSTRUCTIONAL WORK IS OF VERY HIGH QUALITY AND HE USES THE EQUIPMENT SHOWN HERE :

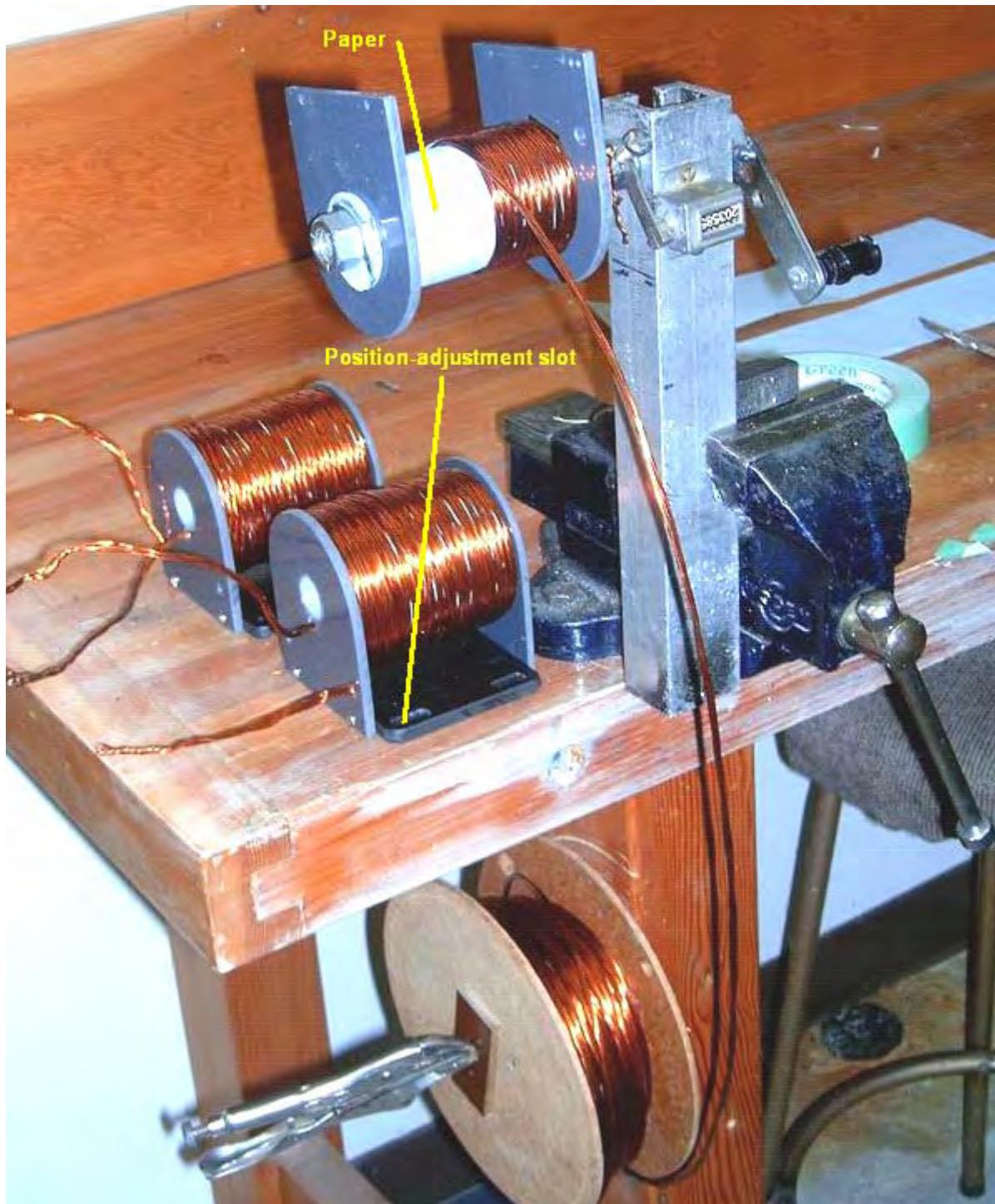

THE THREE COILS PRODUCED THIS WAY WERE THEN ATTACHED TO THE MAIN SURFACE OF THE DEVICE. THERE IS AN ADJUSTABLE GAP BETWEEN THE COILS AND THE ROTOR SO THAT THE OPTIMUM SPACING CAN BE FOUND.

THE MAGNETIC EFFECTS ARE MAGNIFIED BY THE CORE MATERIAL OF THE COILS. THIS CORE IS MADE FROM LENGTHS OF OXYACETYLENE WELDING WIRE WHICH IS COPPER COATED. THE WIRE IS CUT TO SIZE AND COATED WITH SHELLAC TO PREVENT ENERGY LOSS THROUGH EDDY CURRENTS CIRCULATING INSIDE THE CORE.

THE COILS ARE POSITIONED AT EQUAL INTERVALS AROUND THE ROTOR AND SO ARE 120 DEGREES APART. THE END PIECES OF THE COIL FORMERS ARE BOLTED TO A 6mm BASE PLATE WHICH HAS SLOTTED MOUNTING HOLES WHICH ALLOW THE MAGNETIC GAP TO BE ADJUSTED, AS SHOWN HERE :

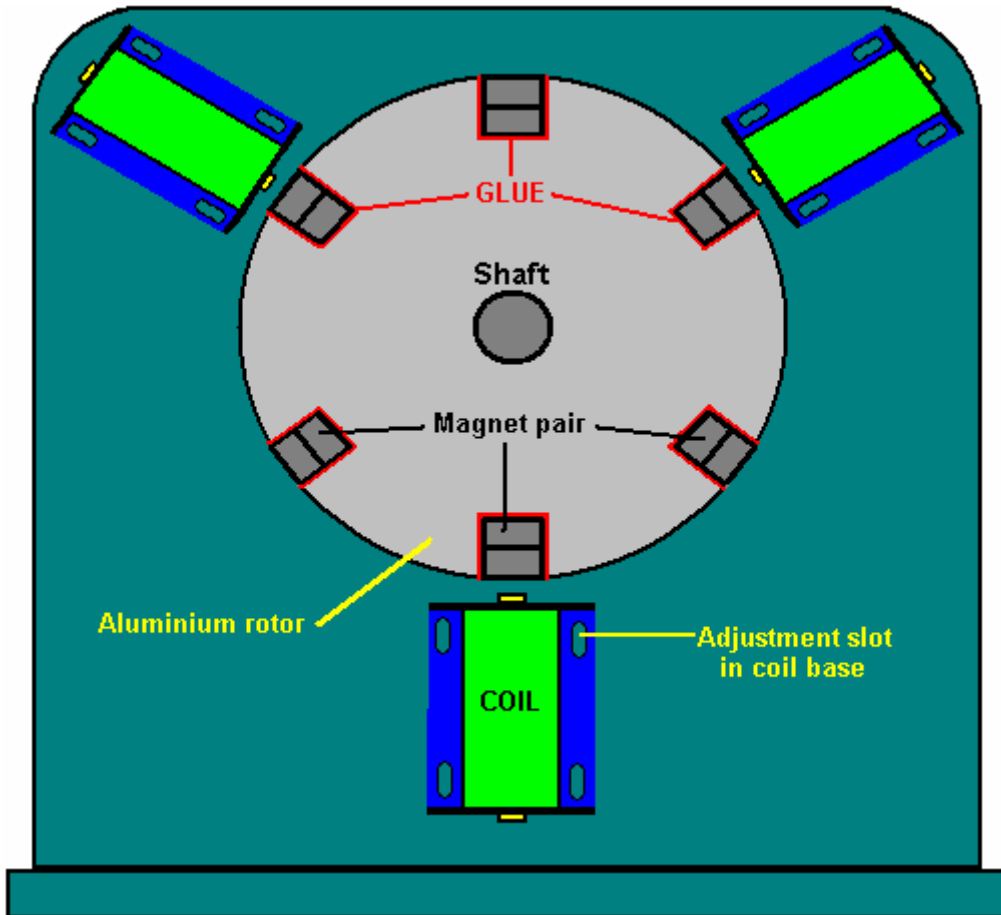

THE THREE COILS HAVE A TOTAL OF FIFTEEN IDENTICAL WINDINGS. ONE WINDING IS USED TO SENSE WHEN THE ROTOR MAGNETS REACH THE COILS DURING ITS ROTATION. THIS WILL HAPPEN SIX TIMES DURING EACH ROTATION AS THERE ARE SIX EVENLY SPACED MAGNETS IN THE ROTOR.

WHEN THE TRIGGER WINDING IS ACTIVATED BY THE MAGNET, THE ELECTRONIC CIRCUIT POWERS UP ALL OF THE REMAINING FOURTEEN COILS WITH A VERY SHARP PULSE WHICH HAS A VERY SHORT RISE TIME AND A VERY SHORT FALL TIME. THE SHARPNESS AND BREVIETY OF THIS PULSE IS A CRITICAL FACTOR IN DRAWING EXCESS ENERGY IN FROM THE SURROUNDING ENVIRONMENT. THE ELECTRONIC CIRCUITRY IS MOUNTED ON THREE ALUMINIUM HEAT SINKS EACH ABOUT 100 x 100mm IN SIZE. TWO OF THESE HAVE FIVE BD243C NPN TRANSISTORS BOLTED TO THEM, AND THE THIRD HAS FOUR BD243C TRANSISTORS MOUNTED ON IT.

THE METAL MOUNTING TAB OF THE TRANSISTOR ACTS AS ITS HEAT SINK AND THAT IS WHY IT IS BOLTED TO THE ALUMINIUM PLATE. THE BD243C TRANSISTOR LOOKS LIKE THIS :

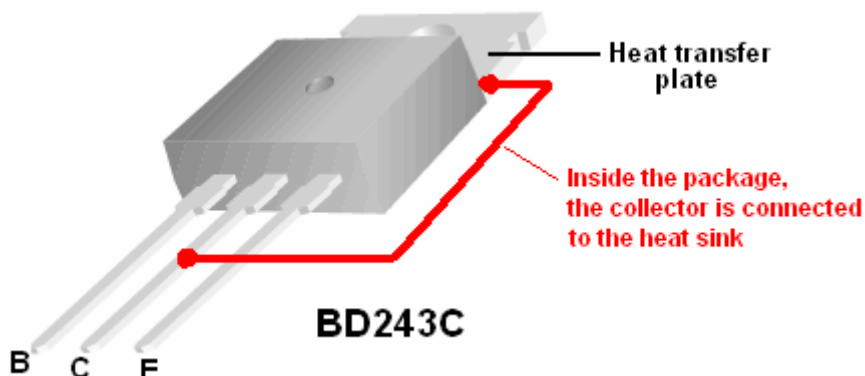

MICA WASHERS ARE PLACED BETWEEN THE TRANSISTORS AND THE ALUMINIUM PLATE AS THAT ALLOWS HEAT TRANSFER BUT NOT ELECTRICAL TRANSFER. THIS AVOIDS UNWANTED CONNECTIONS BEING MADE TO THE OTHER ELECTRONIC COMPONENTS. ORDINARY, HARDWARE STORE SCREW CONNECTOR BLOCKS ARE USED FOR THE WIRE CONNECTIONS :

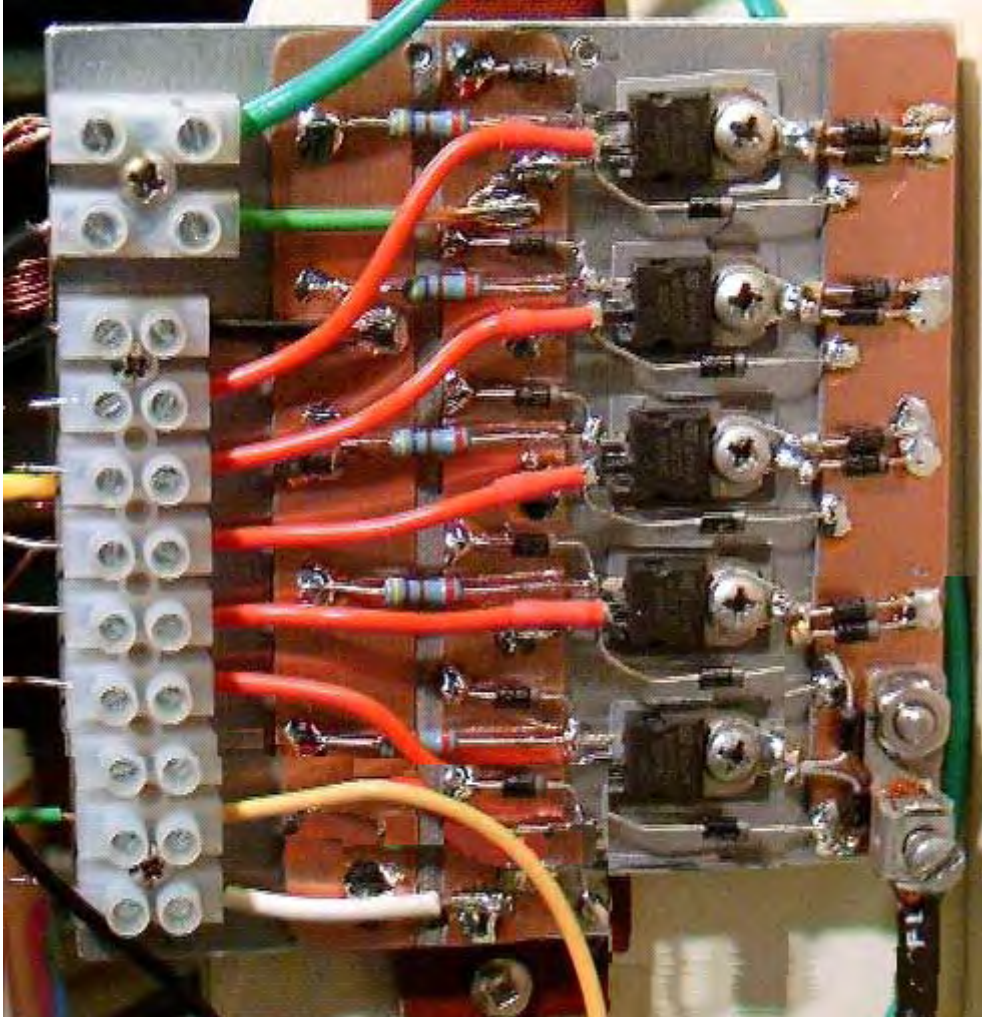

THE CIRCUIT USED FOR THIS DEVICE IS SIMPLE, BUT AS THERE ARE SO MANY COMPONENTS INVOLVED, THE CIRCUIT DIAGRAM IS SPLIT INTO PARTS WHICH FIT ON A PAGE. DIAGRAMS OF THIS KIND ARE USUALLY DRAWN WITH JUST ONE WIRE GOING TO THE TOP OF THE BATTERY WHICH IS BEING CHARGED, BUT IT NEEDS TO BE UNDERSTOOD THAT DRAWING IT THAT WAY IS JUST FOR CONVENIENCE AND BETTER PERFORMANCE IS ACHIEVED IF EACH CHARGING CIRCUIT HAS ITS OWN SEPARATE WIRE GOING TO THE BATTERY BEING CHARGED AS SHOWN IN SECTION 1 HERE :

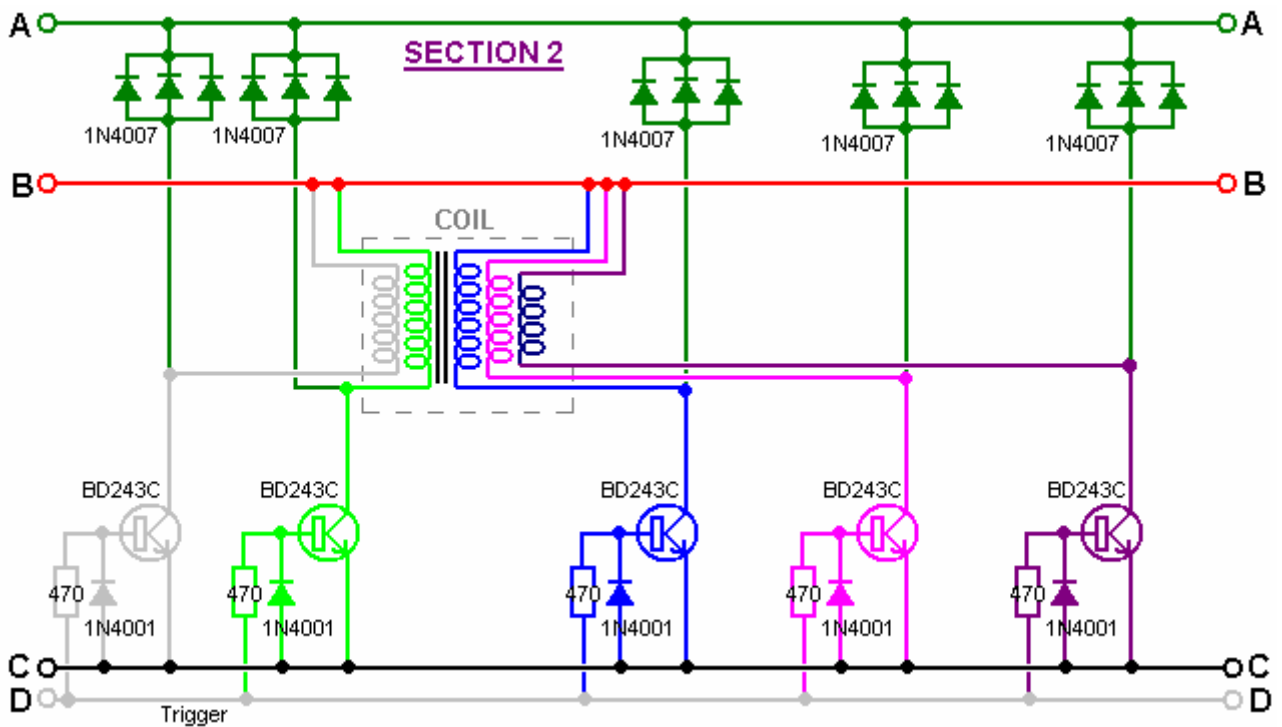
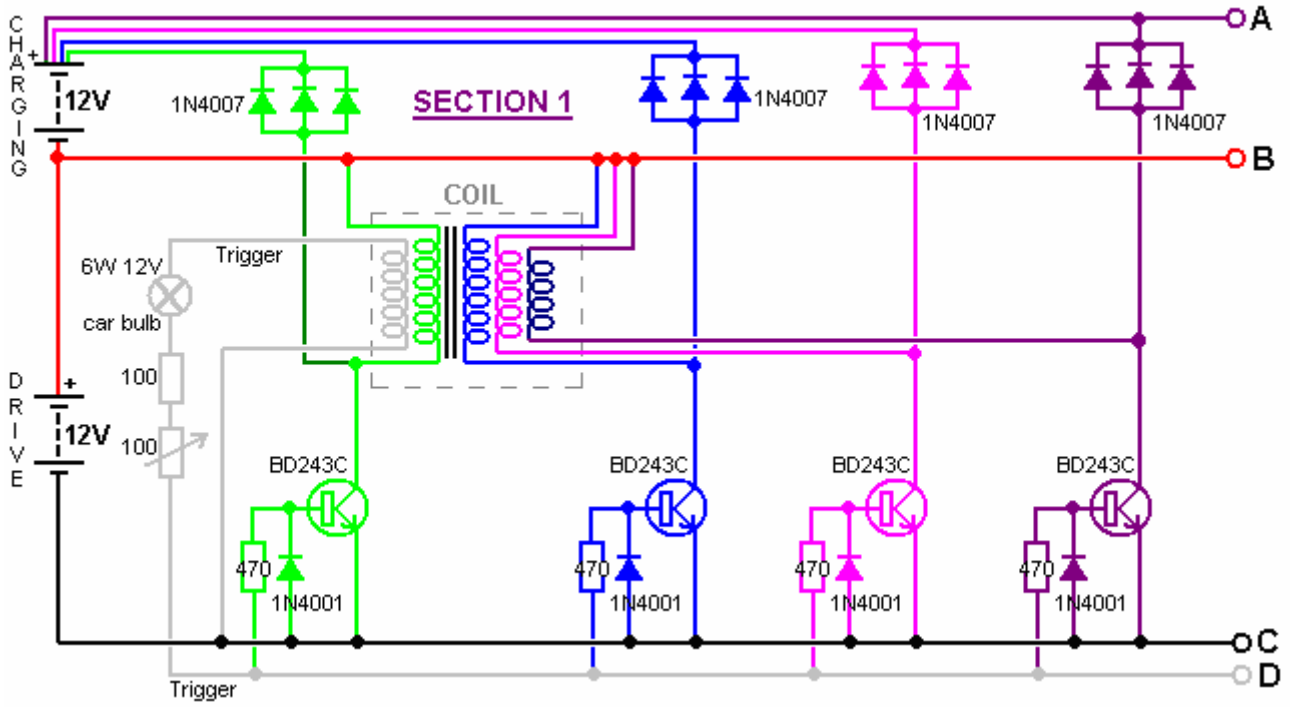

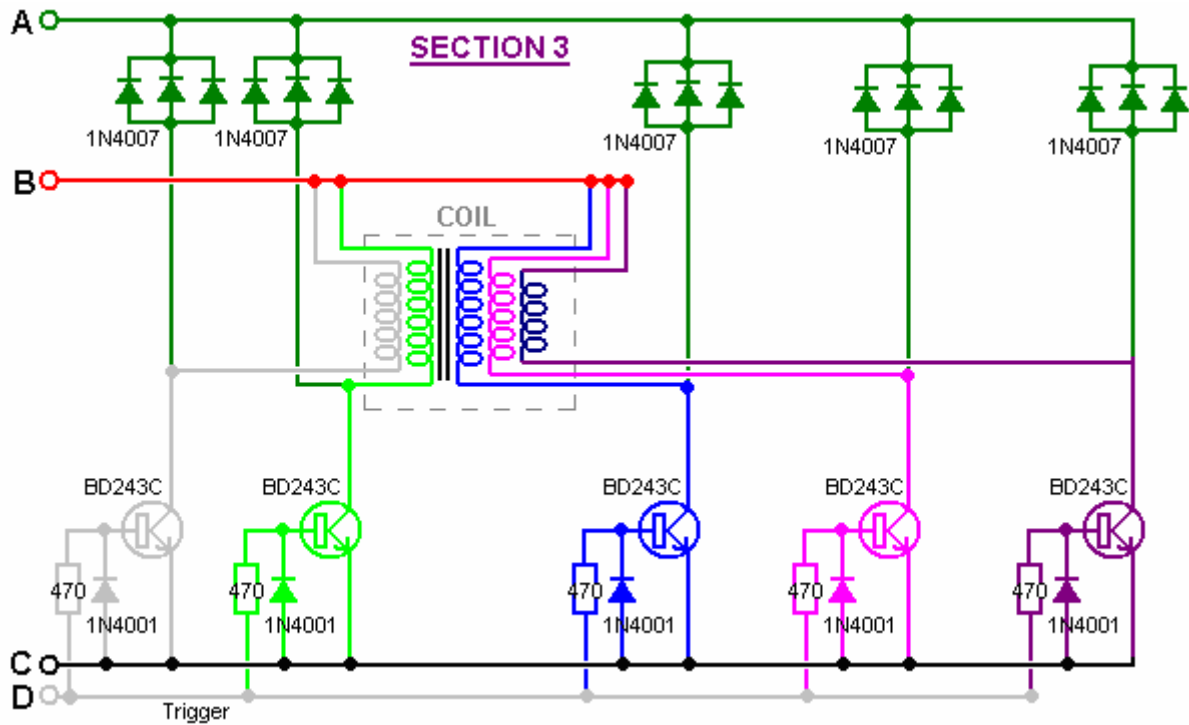

THIS LOOKS LIKE A FAIRLY LARGE AND COMPLICATED CIRCUIT, BUT IT ACTUALLY IS NOT. YOU WILL NOTICE THAT THERE ARE FOURTEEN IDENTICAL CIRCUIT SECTIONS AND EACH OF THOSE IS QUITE SIMPLE :

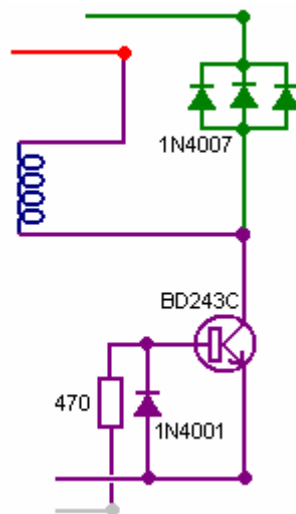

THIS IS A VERY SIMPLE TRANSISTOR CIRCUIT. WHEN A MAGNET PASSES THE COIL, THE GREY TRIGGER WIRE GOES POSITIVE AND THE TRANSISTOR GETS SWITCHED ON HARD, POWERING THE COIL WHICH IS CONNECTED THROUGH THE RED WIRE TO THE DRIVING BATTERY. THE TRIGGER PULSE IS VERY SHORT AND SO THE TRANSISTOR SWITCHES OFF ALMOST IMMEDIATELY. THE SUDDEN SWITCHING OFF OF THE TRANSISTOR CAUSES A MAJOR BACK-EMF VOLTAGE SPIKE TO BUILD UP ACROSS THE COIL. THIS PUSHES THE TRANSISTOR COLLECTOR VOLTAGE UP AND IF IT WERE NOT FOR THE CONNECTION TO THE CHARGING BATTERY, THAT VOLTAGE WOULD REACH HUNDREDS OF VOLTS.

HOWEVER, AS THE VOLTAGE PASSES THE VOLTAGE OF THE CHARGING BATTERY, CURRENT STARTS TO FLOW INTO THE BATTERY BEING CHARGED. THE HIGHER THE VOLTAGE GOES, THE GREATER THE CURRENT FLOWING INTO THE BATTERY. THE COIL HAS LIMITED BACK-EMF POWER AND SO IT CAN'T GET TO TOO HIGH A VOLTAGE AS THE

CURRENT FLOW INTO THE BATTERY LIMITS IT. THAT MEANS THAT YOU DON'T WANT TO HAVE THE CIRCUIT RUNNING IF THE BATTERY BEING CHARGED IS NOT CONNECTED

YOU WILL NOTICE THAT THE CURRENT FED TO THE CHARGING BATTERY GOES THROUGH THREE DIODES INSTEAD OF JUST ONE DIODE. THIS IS GOOD PRACTICE AS IT LOWERS THE RESISTANCE BETWEEN THE TRANSISTOR AND THE BATTERY, RAISES THE CURRENT HANDLING CAPACITY OF THE COMPOSITE DIODE, AND THEN, AS ALREADY MENTIONED, EACH COIL HAS ITS OWN CHARGING WIRE GOING TO THE BATTERY.

THE ONLY OTHER PART OF THE CIRCUIT IS THE SECTION WHICH GENERATES THE TRIGGER SIGNAL WHICH SWITCHES ALL OF THE TRANSISTORS ON TOGETHER :

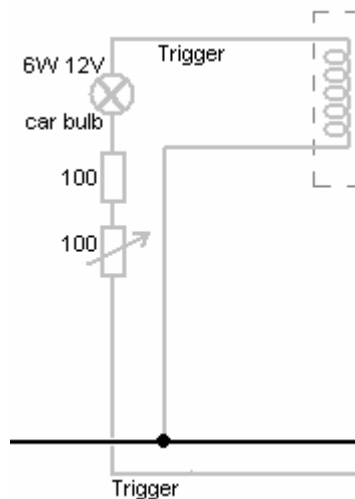

WHEN A MAGNET PASSES THE TRIGGER WINDING, IT GENERATES A VOLTAGE IN THE WINDING. THE STRENGTH OF THE SIGNAL IS KEPT DOWN BY PASSING IT THROUGH A TWELVE VOLT CAR BULB AND THEN A VARIABLE RESISTOR WHICH VARIES BETWEEN 100 OHMS AND 200 OHMS.

THE BULB HAS MORE THAN ONE FUNCTION IN THAT AS WELL AS LIMITING THE CURRENT, IT ALSO GLOWS DIMLY WHICH IS A VERY USEFUL INDICATION OF THE OPERATION OF THE CIRCUIT AS A WHOLE. THE TRIGGER CIRCUIT THEN FEEDS CURRENT TO EVERY TRANSISTOR THROUGH THEIR 470 OHM BASE RESISTORS.

THERE ARE VARIOUS WAYS OF CONSTRUCTING THIS CIRCUIT. RON SHOWS TWO DIFFERENT METHODS. THE FIRST IS TO USE STRIPS OF PAXOLIN PANEL ABOVE THE HEAT SINK IN ORDER TO INSULATE THE COMPONENTS :

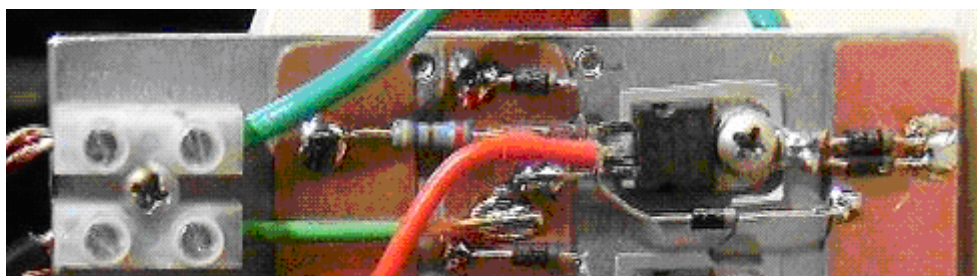

THE SECOND METHOD WHICH IS EASY TO SEE, USES THICK COPPER WIRES HELD CLEAR OF THE ALUMINIUM, TO PROVIDE A CLEAN, LOW-RESISTANCE, SECURE MOUNTING FOR THE COMPONENTS AS SHOWN HERE :

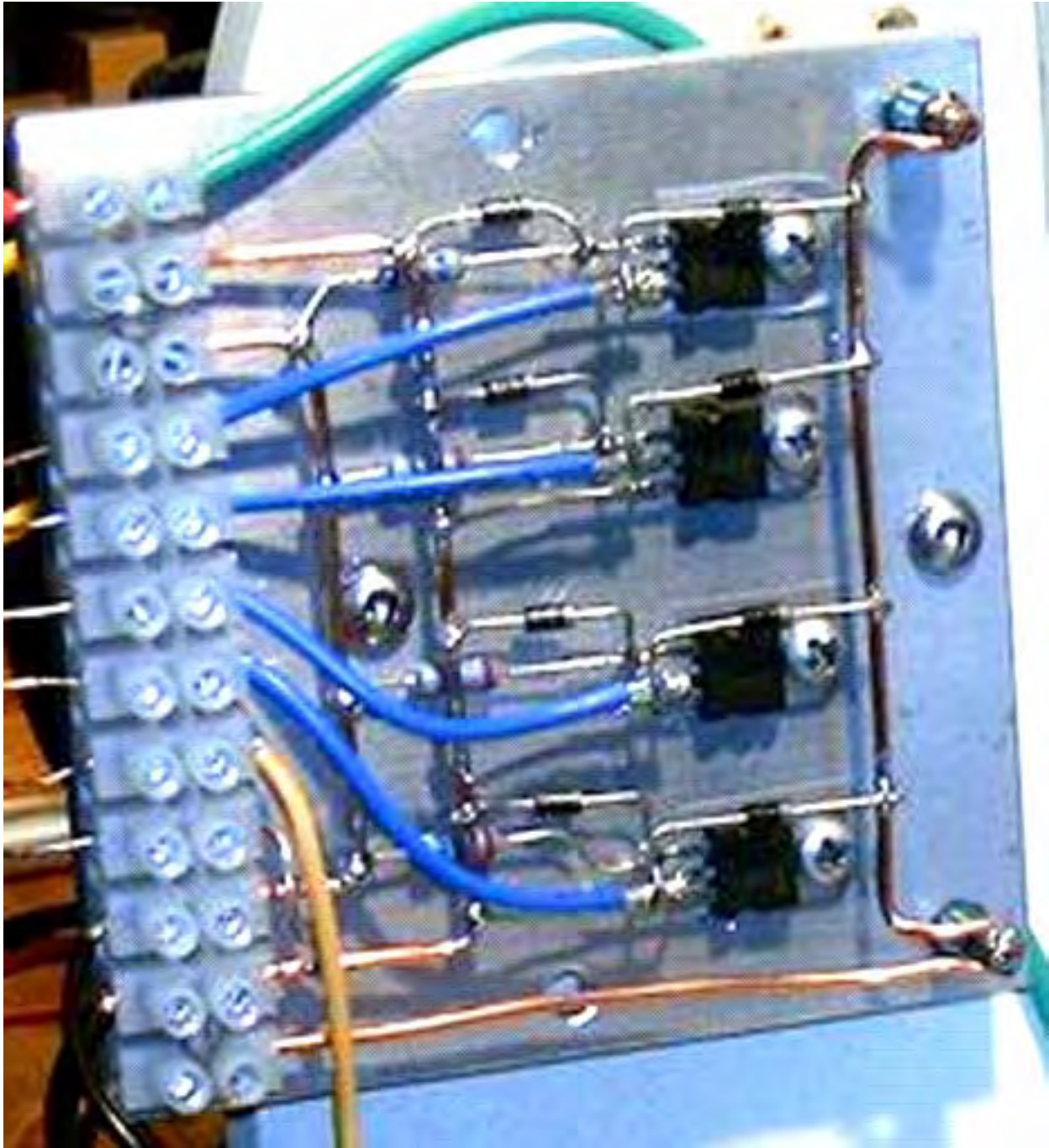

IT IS IMPORTANT TO REALISE THAT THE COLLECTOR OF A BD243C TRANSISTOR IS CONNECTED INTERNALLY TO THE HEAT SINK TAB WHICH IS USED TO MOUNT THE TRANSISTOR. WHILE THE PHOTOGRAPH ABOVE GIVES THE IMPRESSION THAT METAL SCREWS ATTACH THE TRANSISTORS TO THE ALUMINIUM PLATE, THAT IS MOST DEFINITELY NOT THE CASE. INSTEAD, THE METAL BOLTS GO INTO PLASTIC TEE NUTS WHICH PREVENT ANY ELECTRICAL CONNECTION. MICA WASHERS ARE ALSO USED HERE AND THEY ARE AVAILABLE FROM THE SUPPLIERS OF THE TRANSISTORS.

THIS CIRCUIT BOARD IS CONNECTED AT THE REAR OF THE UNIT AS CAN BE SEEN HERE :

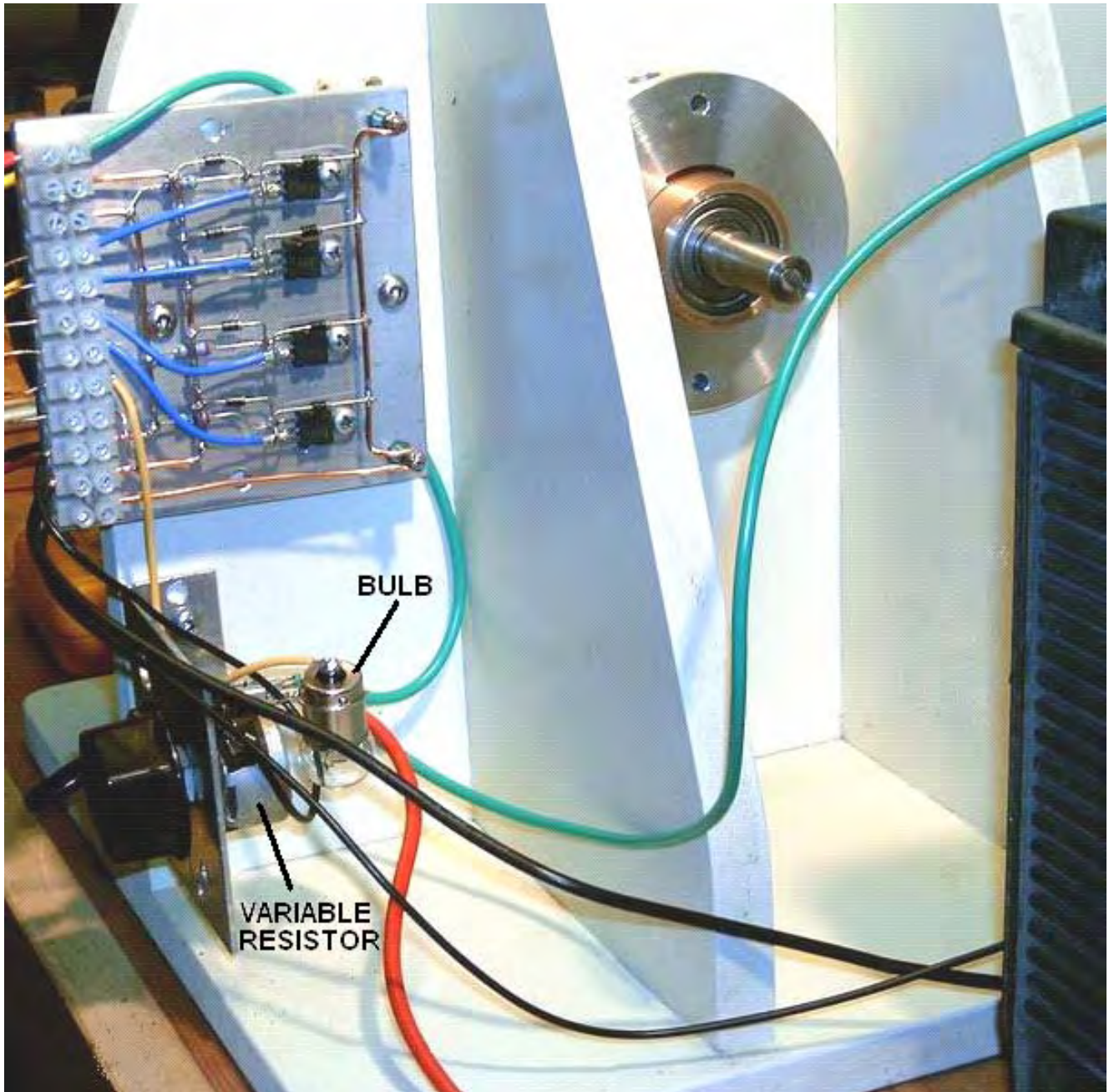

ALTHOUGH THE CIRCUIT DIAGRAM SHOWS A TWELVE-VOLT DRIVE SUPPLY, WHICH IS A VERY COMMON SUPPLY VOLTAGE, RON USUALLY POWERS HIS CHARGER WITH A MAINS OPERATED POWER SUPPLY WHICH DRAWS A PRETTY TRIVIAL 43 WATTS, AND HE CHARGES HIS 24-VOLT BATTERIES USING THE CIRCUIT.

RON USES A VERY NEAT SHEARS ARRANGEMENT FOR CUTTING EXACT LENGTHS OF WELDING ROD WHICH ARE THEN GROUPED TOGETHER TO FORM THE CORE FOR ONE OF HIS 5-STRAND COILS. THAT SHEARING ARRANGEMENT IS SHOWN HERE :



THE DISTANCE BETWEEN THE SHEARS AND THE METAL CLAMPED TO THE WORKBENCH MAKES EACH CUT LENGTH OF WIRE EXACTLY THE SIZE REQUIRED, WHILE THE PLASTIC CONTAINER COLLECTS THE CUT PIECES READY FOR COATING WITH CLEAR SHELLAC OR WITH CLEAR POLYURETHANE BEFORE USE IN THE COIL CORES.

EXPERIENCE IS PARTICULARLY IMPORTANT WHEN OPERATING A CHARGER OF THIS KIND. THE 100 OHM VARIABLE RESISTOR SHOULD BE A WIRE-WOUND TYPE AS IT HAS TO CARRY SIGNIFICANT CURRENT. INITIALLY, THE VARIABLE RESISTOR IS SET TO ITS MINIMUM VALUE AND THE POWER APPLIED. THIS CAUSES THE ROTOR TO START MOVING. AS THE RATE OF SPIN INCREASES, THE RESISTANCE IS GRADUALLY INCREASED AND A MAXIMUM SPEED WILL BE FOUND WITH THE VARIABLE RESISTOR ABOUT THE MIDDLE OF ITS RANGE, THAT IS, AROUND 50 OHM RESISTANCE.

THE NEXT STEP IS TO TURN THE VARIABLE RESISTOR TO ITS MINIMUM RESISTANCE SETTING AGAIN. THIS CAUSES THE ROTOR TO LEAVE ITS PREVIOUS MAXIMUM SPEED OF 1700 RPM AND INCREASE ITS SPEED AGAIN. AS THE SPEED INCREASES, THE VARIABLE RESISTOR IS TURNED GRADUALLY, INCREASING THE RESISTANCE ONCE AGAIN. THIS RAISES THE ROTOR SPEED TO ABOUT 3800 RPM WHEN THE VARIABLE RESISTOR REACHES ITS MID POINT AGAIN.

THIS IS PROBABLY FAST ENOUGH FOR ALL PRACTICAL PURPOSES, AND AT THIS SPEED, EVEN THE SLIGHTEST IMBALANCE OF THE ROTOR SHOWS UP QUITE MARKEDLY. TO GO ANY FASTER THAN THIS REQUIRES AN EXCEPTIONALLY HIGH STANDARD OF

CONSTRUCTIONAL ACCURACY. PLEASE REMEMBER THAT THE ROTOR HAS A LARGE AMOUNT OF ENERGY STORED IN IT AT THIS SPEED AND SO IT IS POTENTIALLY VERY DANGEROUS. IF THE ROTOR BREAKS OR A MAGNET COMES OFF IT, THAT STORED ENERGY WILL PRODUCE A HIGHLY DANGEROUS PROJECTILE. THAT IS WHY IT IS ADVISABLE, ALTHOUGH IT IS NOT SHOWN IN THE ABOVE PHOTOGRAPHS, TO CONSTRUCT AN ENCLOSURE FOR THE ROTOR. THAT COULD BE A U-SHAPED CHANNEL BETWEEN THE COILS, AND IT WOULD CATCH AND RESTRAIN ANY FRAGMENTS SHOULD ANYTHING BREAK LOOSE.

IF YOU WERE TO MEASURE THE CURRENT DURING THIS ADJUSTMENT PROCESS, IT WOULD BE SEEN TO REDUCE AS THE ROTOR SPEEDS UP. THIS LOOKS AS IF THE EFFICIENCY OF THE DEVICE IS RISING. THAT MAY BE SO, BUT IT IS NOT NECESSARILY A GOOD THING IN THIS CASE WHERE WE WANT TO PRODUCE RADIANT ENERGY CHARGING OF A BATTERY BANK. IT HAS BEEN SHOWN THAT SERIOUS CHARGING TAKES PLACE BETWEEN 3 AMPS TO 5 AMPS OR MORE CURRENT DRAW AT MAXIMUM ROTOR SPEED AND NOT A MISERLY 50 MILLIAMPS CURRENT DRAW WHICH CAN BE ACHIEVED BUT WHICH DOES NOT PRODUCE GOOD CHARGING. THE POWER CAN BE INCREASED BY RAISING THE INPUT VOLTAGE TO 24 VOLTS OR EVEN HIGHER. SOME PEOPLE OPERATE AT 48 VOLTS RATHER THAN 12 VOLTS.

THE DEVICE CAN BE FURTHER TUNED BY STOPPING IT AND ADJUSTING THE GAP BETWEEN THE ROTOR AND THE COILS AND THEN REPEATING THE START-UP PROCEDURE. THE OPTIMUM ADJUSTMENT IS WHERE THE FINAL ROTOR SPEED IS THE HIGHEST.

THESE NOTES ARE AT : <http://www.free-energy-info.com/Pugh.pdf>

THE EBOOK IS AT : <http://www.free-energy-info.com/PJKbook.pdf>