



US 20110113772A1

(19) **United States**

(12) **Patent Application Publication**

Rohner

(10) **Pub. No.: US 2011/0113772 A1**

(43) **Pub. Date: May 19, 2011**

(54) **PLASMIC TRANSITION PROCESS MOTOR**

(57) **ABSTRACT**

(75) Inventor: **John P. Rohner**, South English, IA (US)

(73) Assignee: **PlasmERG, Inc.**

(21) Appl. No.: **12/592,117**

(22) Filed: **Nov. 18, 2009**

Publication Classification

(51) **Int. Cl.**
F01B 29/10 (2006.01)

(52) **U.S. Cl.** **60/509**

An internal expansion engine having a housing. Secured to the housing is a cylinder defining an expansion chamber. A piston is provided within the cylinder defining a wall of the expansion chamber. A charge of noble gas is provided within the expansion chamber. A magnetic field generator and radio frequency power generator is provided around the expansion chamber and an initiator system is located within the expansion chamber. The magnetic field generator, radio frequency power generator and initiator system coact to cause the noble gas to expand, pushing against the piston and generating work. The actions of the engine are monitored and controlled by an intelligent electronic control system that provides all switching needed to operate the engine and communicate with outside elements providing external control of information sources.

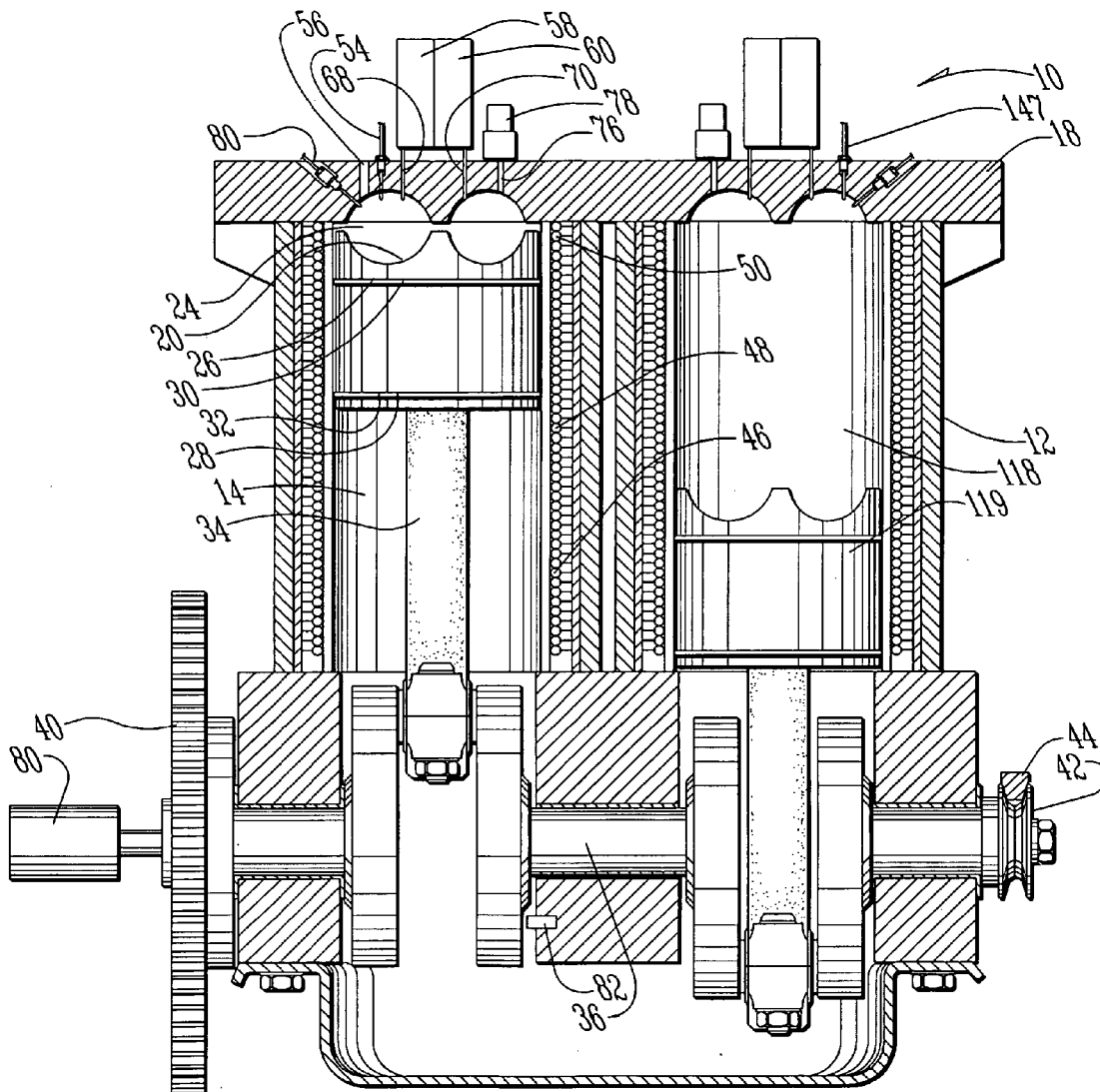

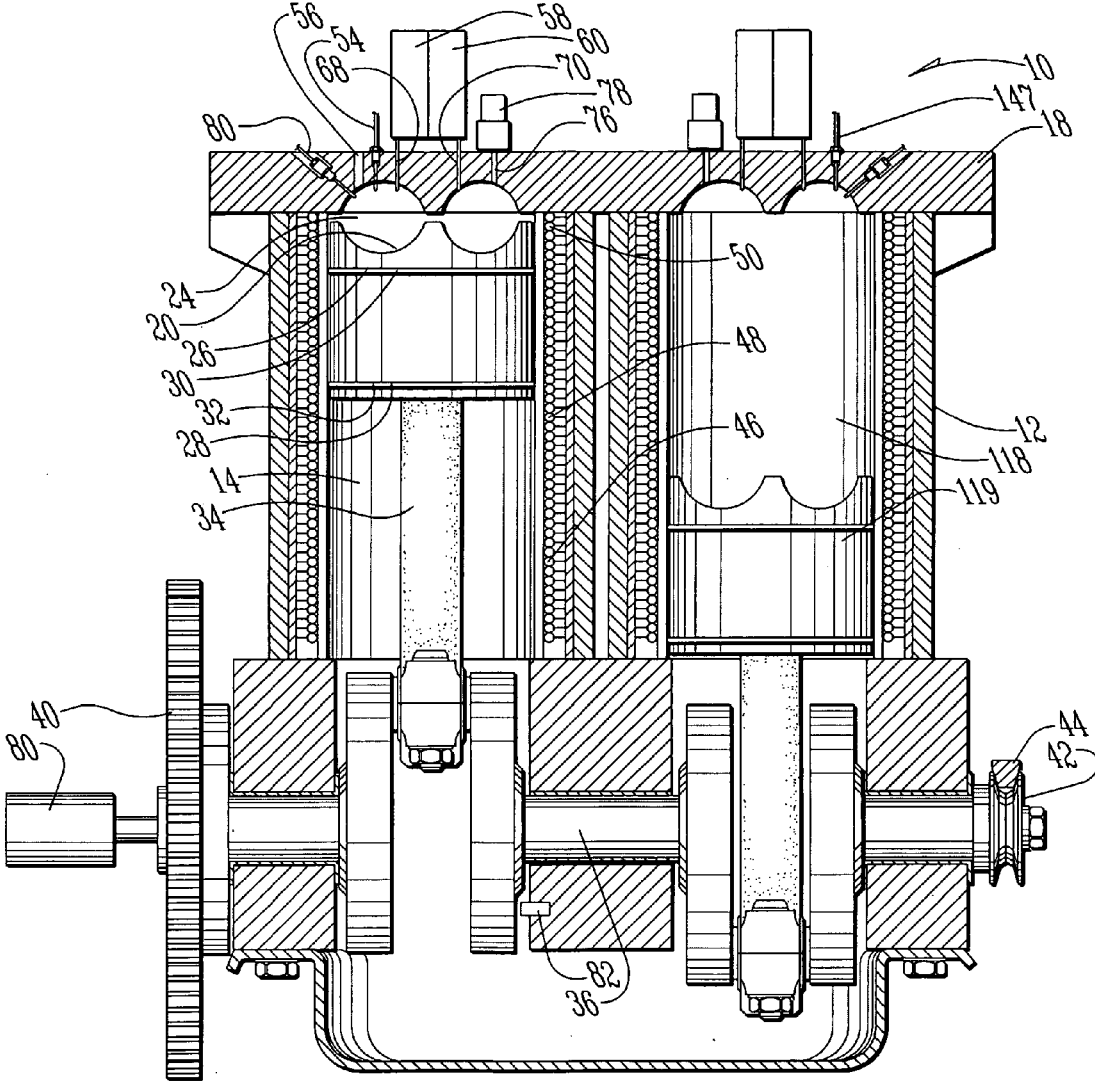

FIG. 1

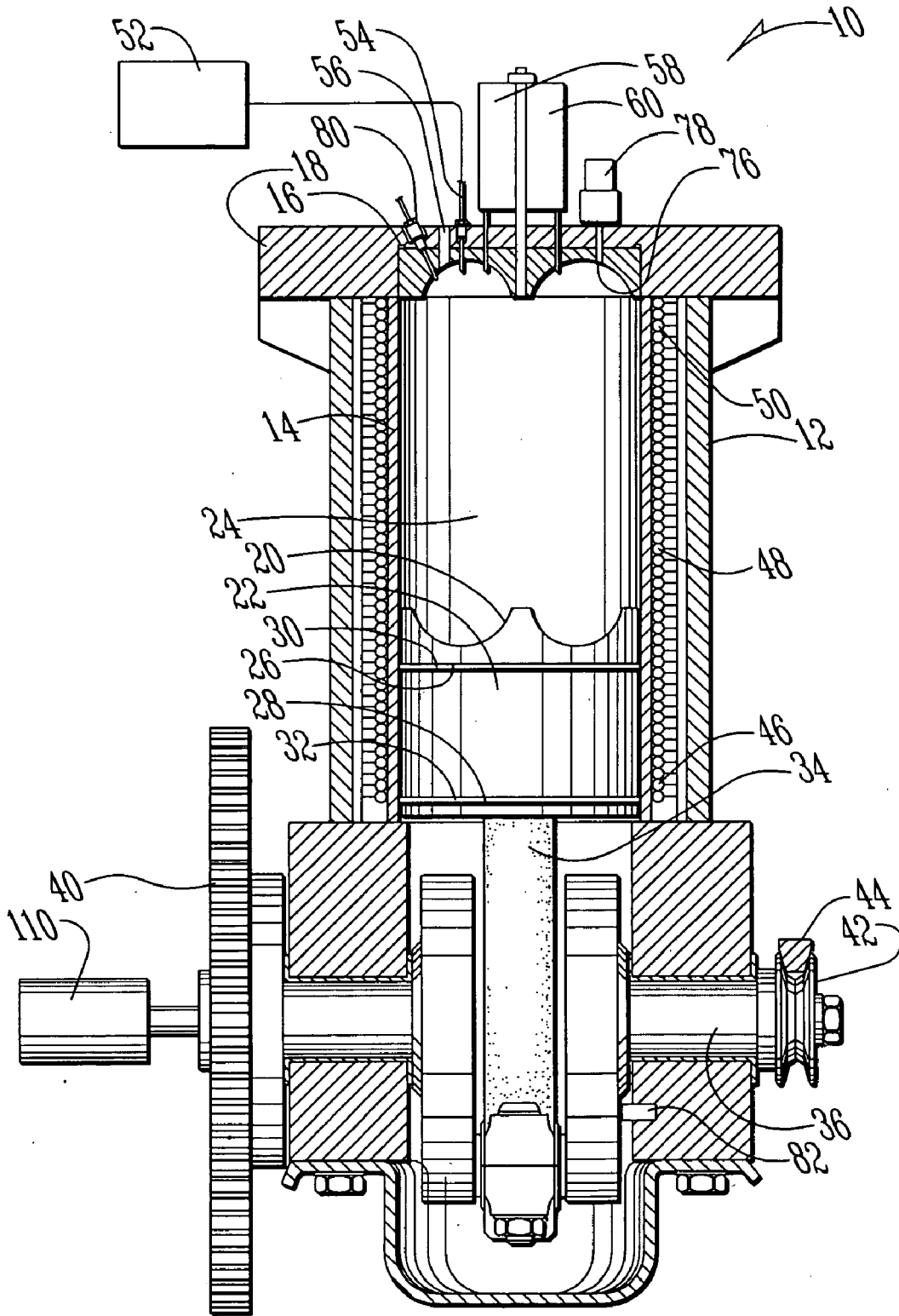

FIG. 2

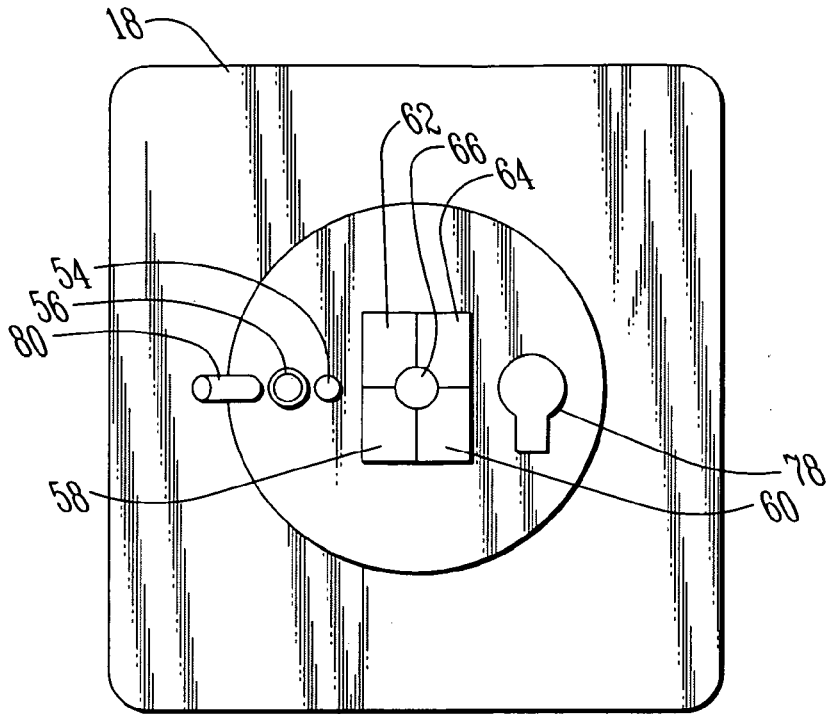

FIG. 3

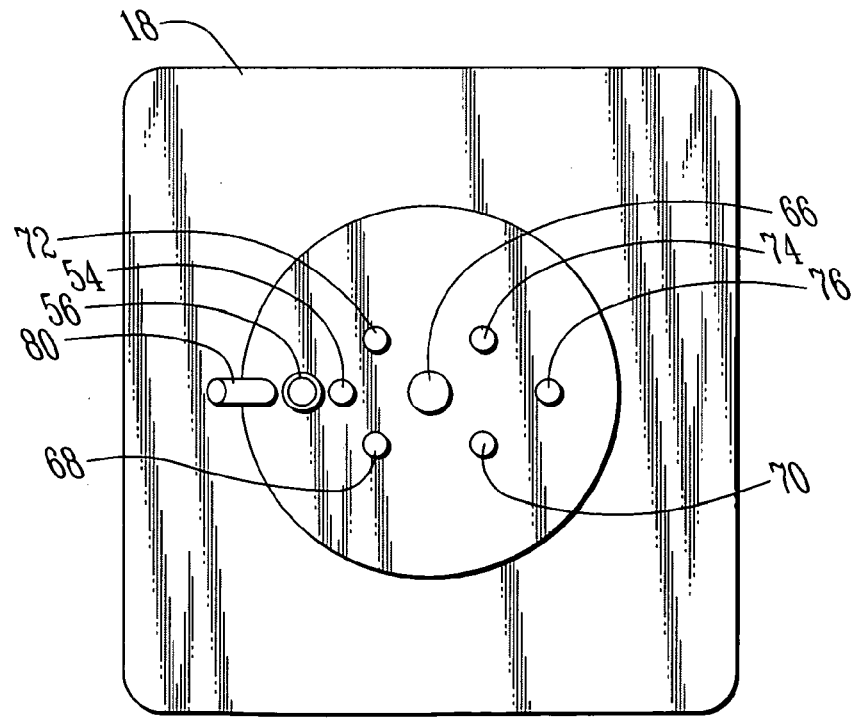

FIG. 4

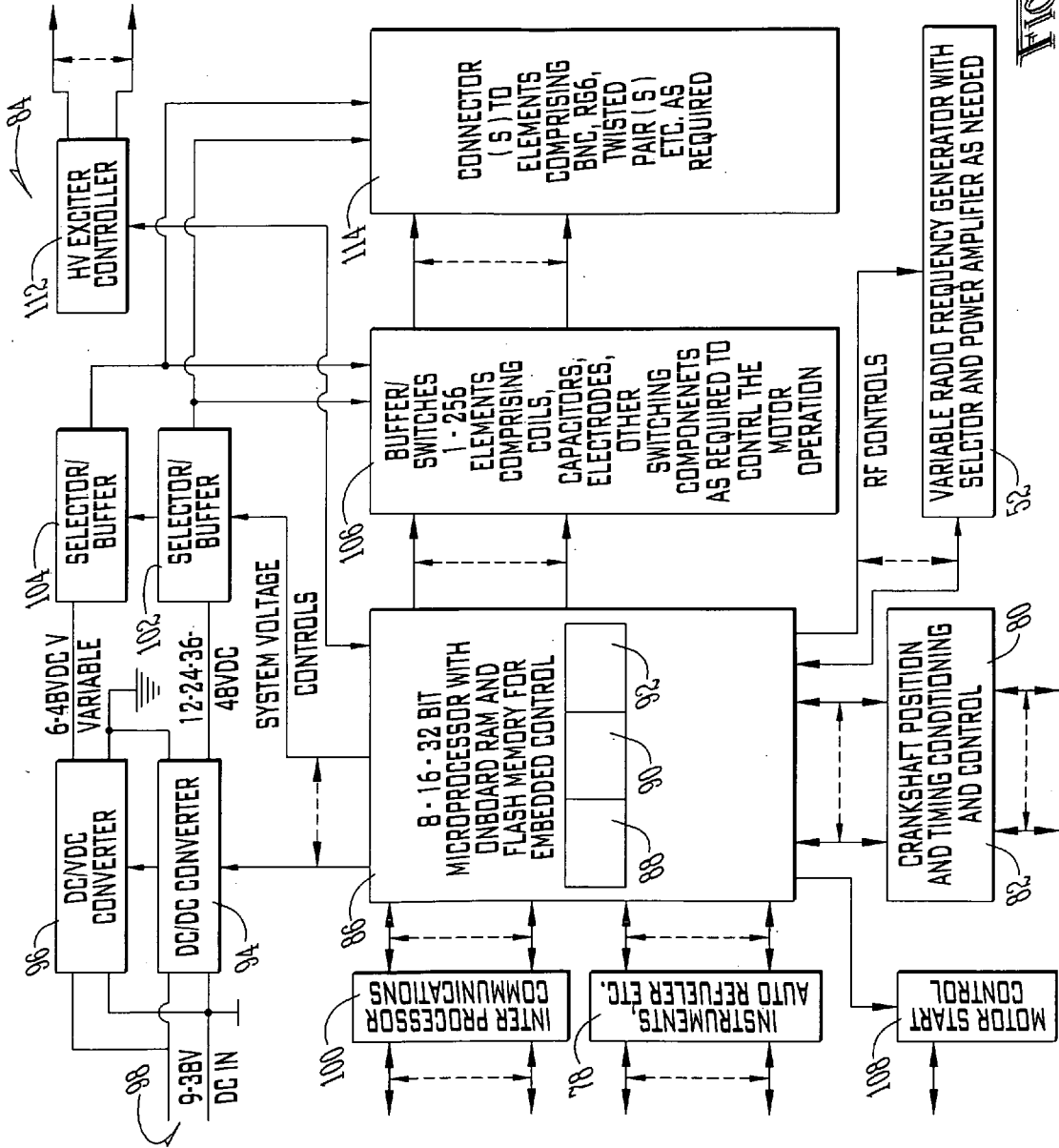
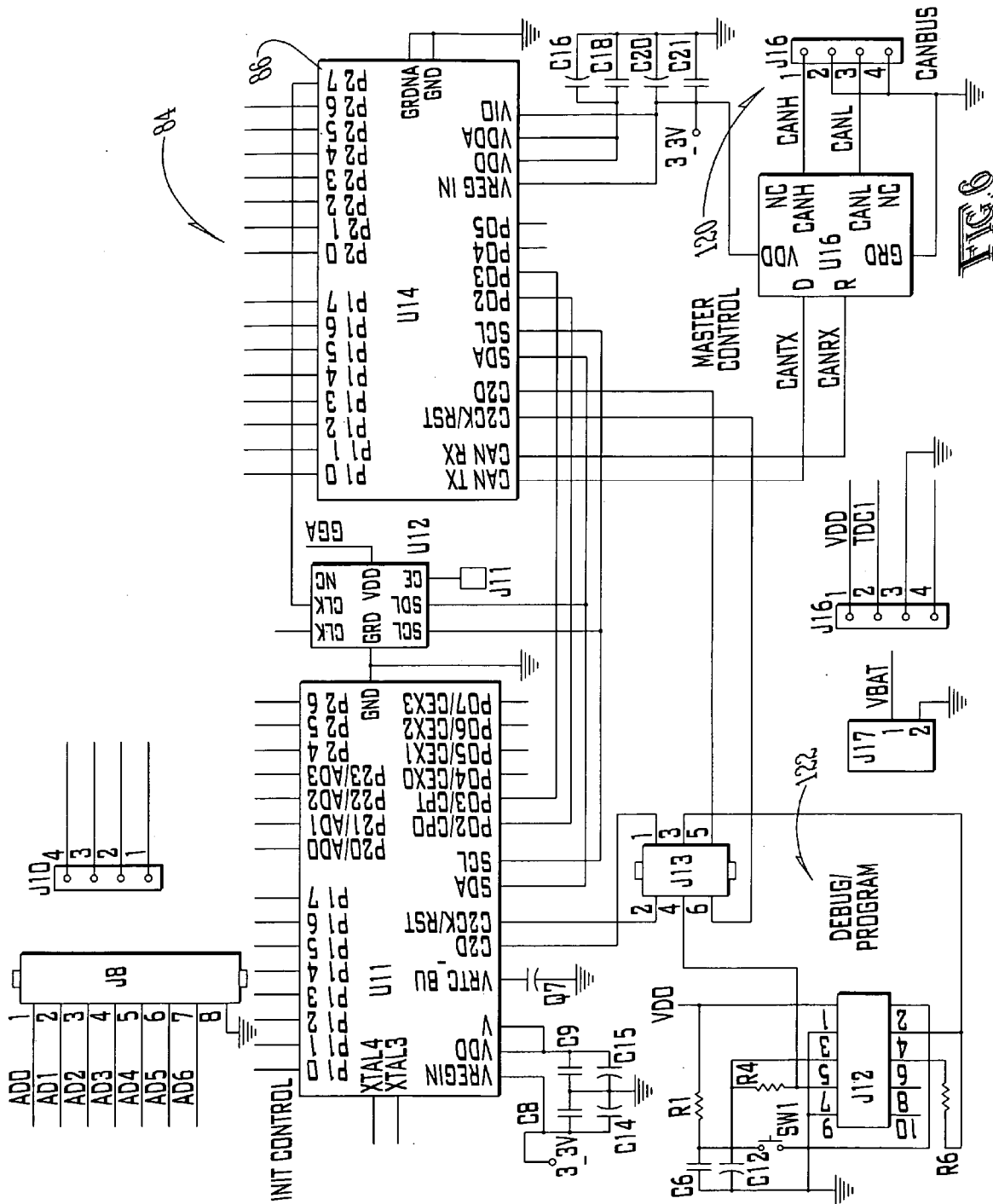

FIG. 5



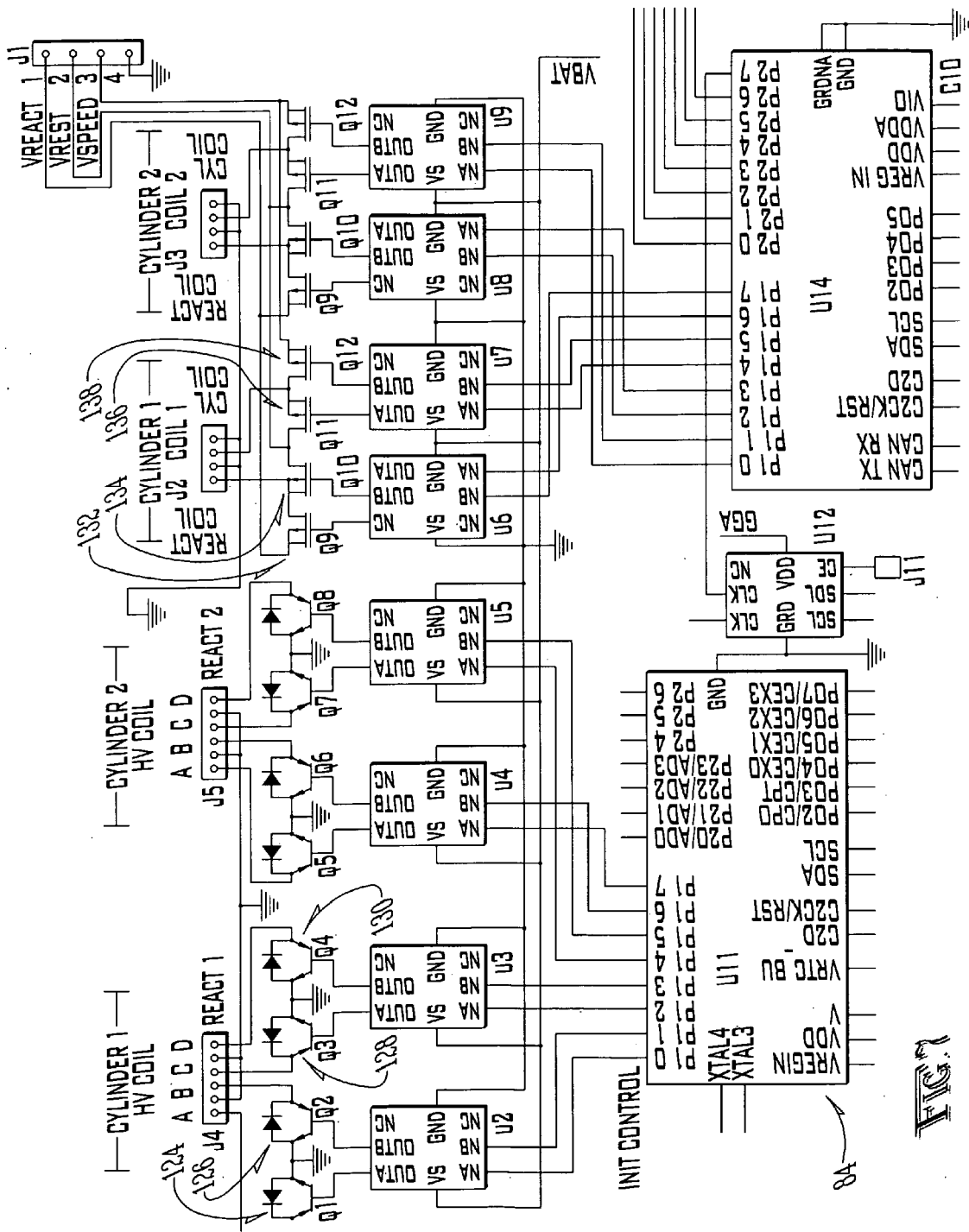

FIG. 1

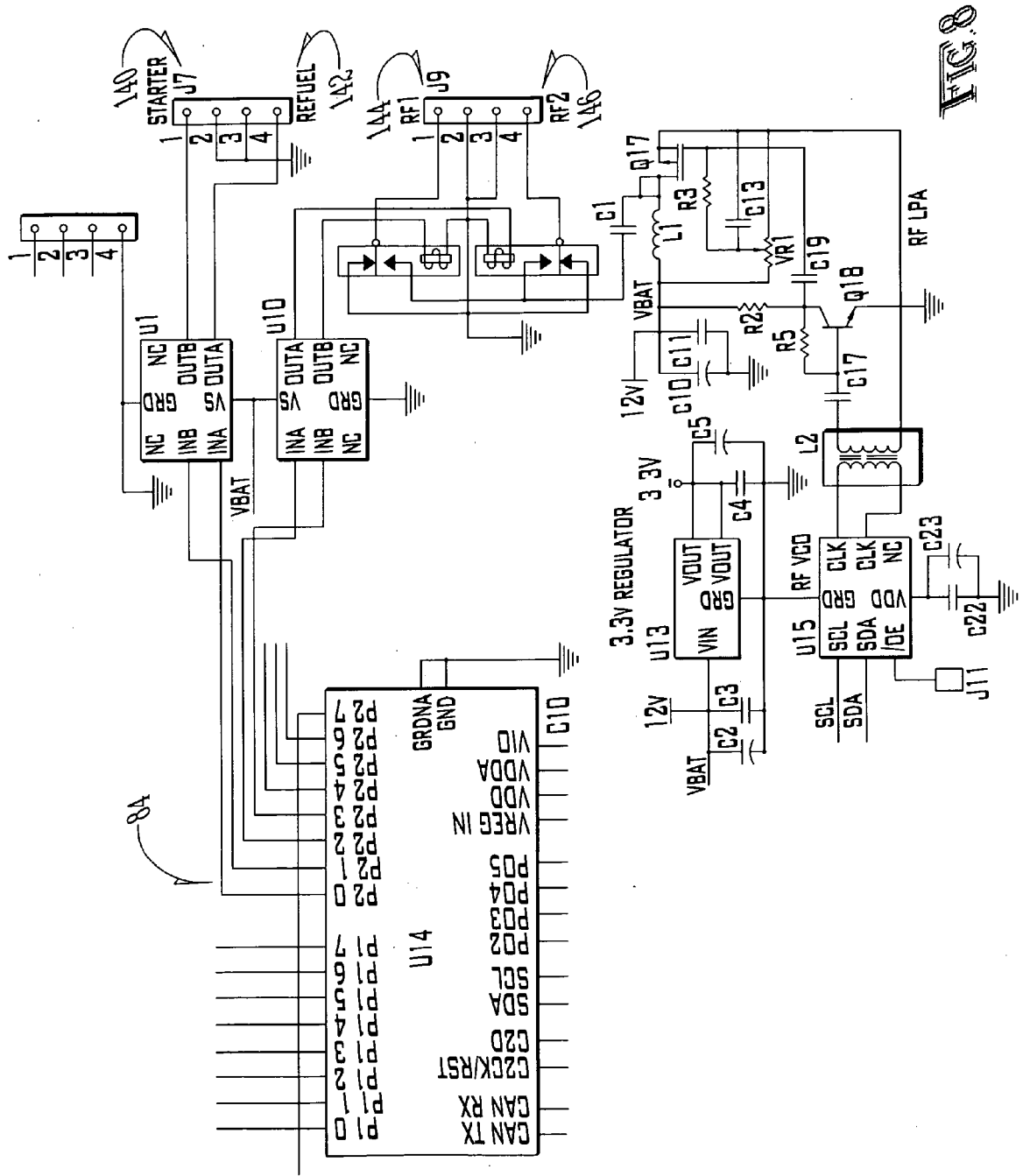

FIG. 8

PLASMIC TRANSITION PROCESS MOTOR

[0001] This patent application claims priority to U.S. Provisional Patent Application Ser. No. 60/412,230 filed Nov. 19, 2008.

TECHNICAL FIELD

[0002] The present invention relates to an engine and more particularly to an engine utilizing the Plasmic Transition Process and controlled by a flexible electronic control system.

BACKGROUND

[0003] Internal combustion engines are well known in the art. The operation of such engines involves the combustion of a fossil fuel within a cylinder to drive a piston to generate work. Such prior art internal combustion engines have several drawbacks. One drawback is the inefficiency of such engines. As it is difficult to translate all of the power from the combustion into work, commercial internal combustion engines typically have less than fifty percent efficiency. Another drawback is the pollution created when internal combustion engines expel carbon dioxide and other damaging material into the air. Yet another drawback of prior art internal combustion engines is the heat generated by the engines, which requires a separate cooling system to prevent damage to the engine during operation.

[0004] It is also known in the art to provide an engine utilizing non-combustible gases in lieu of combustible gases. Examples of such devices can be found in U.S. Pat. Nos. 3,670,494; 4,428,193; and 7,076,950. One drawback associated with such prior art devices is the difficulty associated with operating them continuously for a long period of time. The temperamental nature of the ionization process involved with such prior art devices makes it difficult to incorporate them into vehicles and other items which require a minimum level of reliability. The difficulties encountered in the prior art discussed hereinabove are substantially eliminated by the present invention.

SUMMARY OF THE DISCLOSED SUBJECT MATTER

[0005] In an advantage provided by this invention, an internal expansion engine is provided which is of a low-cost, lightweight manufacture.

[0006] Advantageously, this invention provides a sealed environment with substantially no harmful exhaust.

[0007] Advantageously, this invention provides an engine which requires little fuel.

[0008] Advantageously, this invention provides an engine which requires little maintenance.

[0009] Advantageously, in the preferred embodiment of this invention, an internal expansion engine is provided. The engine is provided with a housing having a cylinder defining an expansion chamber. Provided within the cylinder is a piston forming a wall of the expansion chamber. Provided within the expansion chamber is a charge of a gas mixture. A magnetic field generator is provided around the expansion chamber, and Radio Frequency power input is coupled to the expansion chamber. An initiator system is located within the expansion chamber to coact with the magnetic field generator

and Radio Frequency power input to generate a plasma and generate work in the form of movement of the piston.

BRIEF DESCRIPTION OF THE DRAWINGS

[0010] The present invention will now be described, by way of example, with reference to the accompanying drawings in which:

[0011] FIG. 1 illustrates a side elevation in cross-section of one instance of an engine of the present invention;

[0012] FIG. 2 illustrates a side elevation in cross-section of one cylinder assembly of the engine of the present invention;

[0013] FIG. 3 illustrates a top plan view of the cylinder head of the present invention;

[0014] FIG. 4 illustrates a bottom plan view of the cylinder head of the present invention;

[0015] FIG. 5 illustrates a block diagram of the electronic control unit of the present invention;

[0016] FIG. 6 illustrates a schematic of the electronic control unit of the present invention;

[0017] FIG. 7 illustrates a schematic of the electronic control unit coupled to the starter, refueling and radio frequency controllers; and

[0018] FIG. 8 illustrates a schematic of the electronic control unit coupled to the high voltage coils and the coils provided around the cylinder.

DETAILED DESCRIPTION OF THE DRAWINGS

[0019] A motor according to the present invention is shown generally as 10 in FIG. 1. The motor (10) comprises a casing (12) housing a cylinder (14). The cylinder (14) is constructed of a non-ferrous material, such as hard coat aluminum, and has no air intake or exhaust. The cylinder (14) is sealed on one end by a circular seal (16) to a cylinder head (18) on the other end by the head (20) of a piston (22). (FIGS. 1 and 2). The cylinder head (18) and piston (22) are constructed of a Ferro-magnetic material such as Grade 416 stainless steel. The cylinder (14), circular cylinder head (18) and circular head (20) of the piston (22) form the walls of an expansion chamber (24). When the piston (22) is at the top dead center (TDC) position as shown in FIG. 2, the circular cylinder head (18) and circular head (20) of the piston (22) form a toroidal transition chamber (25). The cylinder head (18) and head (20) of a piston (22) are provided with a mirrored finish to increase the efficiency of the transition chamber (25).

[0020] The piston (22) is provided with ring grooves (26) and (28), within which rest piston rings (30) and (32), such as those known in the art. The piston rings (30) and (32) form a seal between the piston (22) and cylinder (14), preventing the passage of gases thereby. The piston (22) is pivotally coupled to a connecting rod (34). The connecting rod (34) is coupled to a crankshaft (36), which is journaled to a crankcase (38). The crankcase (38) is coupled to the casing (12). Coupled to one end of the crankshaft (36) is a flywheel (40). Coupled to the other end of the crankshaft (36) is a V-belt drive pulley (42) provided with a V-belt (44).

[0021] As shown in FIG. 1, provided between the casing (12) and the cylinder (14) are three coils (46), (48) and (50). The supplemental coil (46) is preferably constructed of between 100 and 500 turns, and most preferably 220 turns, of 20 gauge wire. The supplemental coil (46) is approximately 20 centimeters long. The cylinder coil (48) is preferably constructed of between 200 and 900, and most preferably 600 turns of 18 gauge wire. The cylinder coil (48) is approxi-

mately 15.0 centimeters long. The transition coil (50) is preferably constructed of between 50 and 100, and most preferably 80 turns of 18 gauge wire. The transition coil (50) is approximately 4.5 centimeters long. The supplemental coil (46) may act as a capacitor when charged, or as an electromagnetic shield when uncharged. When the piston (22) is at TDC the cylinder coil (48) is located completely below the head (20) of the piston (22) and the transition coil (50) completely surrounds the transition chamber (25). The cylinder coil (48) acts as a magnetic field generator on the interior of the cylinder (14). The transition coil (50) also acts as a magnetic field generator on the interior of the cylinder (14), but is primarily focused to generate a predetermined magnetic field within the expansion chamber (24) when the piston (22) is near the TDC position. In the preferred embodiment, only the cylinder coil (48) and transition coil (50) are used.

[0022] A ionization generator, such as a radio frequency generator (52) coupled to a high frequency antenna (54) is provided to act on the gas within the transition chamber (25) to ionization. The antenna (54) is preferably constructed of 18 gauge wire between 5.0 and 10.0 centimeters in length and most preferably 8.1 centimeters in length wrapped 60% around the Transition chamber at mid point within the toroidal structure. An alternate way to perform this function could also be to modulate the transition coil (50) with this RF power.

[0023] As shown in FIG. 1, the high frequency antenna (54) is secured through the cylinder head (18) and extends into the expansion chamber (24). An initiator system is provided, such as a high voltage coil (58) or multiple coils (58), (60), (62), (64), such as "coil on plug" spark coils, such as those known in the art, provided with a 55 KV output sufficient to generate a arc of 140 KV and long enough duration to induce transition of the ionized gas mixture within the transition chamber (25).

[0024] If desired, the cylinder head (18) may be provided with a clear glass port (56) to allow visual access to the expansion chamber (24). An initiator system, such as four high voltage coils (58), (60), (62) and (64) and an arc return element (66) are secured to the cylinder head (18). (FIGS. 1-4.) Four high voltage electrodes (68), (70), (72) and (74) depending from the four high voltage coils (58), (60), (62) and (64), extend through the cylinder head (18) and into the expansion chamber (24). The arc return element (66), which is a 0.6 centimeter diameter copper screw, also extends through the cylinder head (18) into the expansion chamber (24). An alternate to this is to use an aluminum post with a small pod at the end within which would be strontium or a similar accelerant.

[0025] As shown in FIG. 1, provided on the cylinder head (18) is a refueling port (76), provided with a valve (78) to allow infusion of a gas into the expansion chamber (24) without having to disassemble the motor (10). Also provided on the cylinder head (18) is a system sensor (80). The sensor (80) is an insulated length of 18 gauge copper wire that protrudes 2 mm into the transition chamber. This sensor (80) connects to the Electronic Control System (84) and detects the status of Plasmic Transition Process sequence.

[0026] A sensor (82) such as those known in the art, is coupled to the crankshaft (36) to indicate the position of the piston (22) relative to the TDC position. Alternatively, a magnet may be mounted to the flywheel (40) and a Hall Effect switch mounted in a stationary position in the crankcase (38), and actuated by the magnet as the magnet comes into proximity with the Hall Effect switch.

[0027] The electronic control system (ECS) of the present invention is shown generally as (84) in FIG. 5. The ECS (84) includes an embedded control system (86), provided with a central processing unit, such as a microprocessor (88), onboard RAM (90) and flash memory (92). In this embodiment the 8-bit microprocessor (88) can control 24 lines providing selective switching of up to 8 Coils and 8 voltage lines. As shown in the schematic of FIG. 6, to accommodate more lines, additional processors (100) may be used. Alternatively, larger 16-bit, 32-bit or 64-bit processors may be used.

[0028] Coupled to the embedded control system (86) are two DC to DC converters (94) and (96) which are in turn coupled to a battery (98). (FIG. 5). The battery (98) is preferably between 9-38 VDC. The first converter (94) converts voltage from the battery (98) to 12, 24, 36 or 48 VDC. The second converter (96) is digital programmed variable, configured to convert voltage from the battery (98) to 6 to 48 VDC as desired to control the speed voltage used by the engine electromagnetic coils for operation of the variable speed of the motor (10) and to accommodate various fuel mixtures wherein. The embedded control system (86) uses selector/buffers (102) and (104) coupled to the converters (94) and (96) to vary the voltage output to the switch controller (106). The switch controller (106) is an 8-bit microprocessor which controls the switching of the various components of the motor (10). The switch controller (106) is buffered from the high energy switching of Coils, IGBT, and expansion chamber electromagnetic coils and DMOSFET, by driver buffer circuits to insure safety.

[0029] The ECS (84) is coupled to the crankshaft sensor (82) and the sensor (80) provided within the transition chamber (25) to allow the ECS (84) to determine the status of plasma transition. (FIGS. 1-5). The ECS (84) may also be coupled to other instruments, such as the valve (78) coupled to the refueling port (76), to allow the ECS (84) to trigger automatic refueling of the motor (10). The ECS (84) is coupled to a starter (108) which in turn is coupled to an electric motor (110) coupled to the flywheel (40). The radio frequency generator (52) is coupled to the ECS (84), allowing the ECS (84) to be programmed to generate various radio frequencies for use as speed changes and to accommodate various designs of the motor (10), fuel mixtures.

[0030] The second selector/buffer (104) and ECS (84) are coupled to a high voltage controller (112), which in turn is coupled to the four high voltage coils (58), (60), (62) and (64). The switch controller (106) and the selector/buffers (102) and (104) are coupled to a male connector (114) to allow the ECS (84) to be connected to the coils (46), (48) and (50) and any other components of the motor (10) desired to be controlled by the ECS (84). These switches are high power IGBT devices to control the coil dwell or high power DMOSFET switches for the electromagnetic coils.

[0031] As seen from FIG. 5, the ECS (84) controls the conversion of input voltage from the battery (98) to the voltage for recharging the four high voltage coils (58), (60), (62) and (64), as well as the variable voltage output to the coils (46), (48) and (50), to control the speed of the motor (10). The ECS (84) also controls the power and frequency of the RF signal generated by the radio frequency generator (52) to accommodate motor design, desired speed and fuel mixture requirements.

[0032] FIGS. 6-8 show schematics of the ECS (84) for motor (10) of the present invention provided with the supplemental cylinder assembly (118), of a construction similar to

that described above and controlled by the ECS (84). The supplemental cylinder assembly (118) is positioned parallel to the cylinder (14), having a piston (119) offset one stroke from the piston (22) and coupled to the crankshaft (22) to drive the crankshaft (22) and flywheel (40) when the piston (22) is on its recovery stroke. (FIG. 1). As shown in FIG. 6, the ECS (84) has a Controller Area Network (CAN) bus interface (120), allowing various components of the motor control systems (10) to communicate directly with one another, or with components of a vehicle (not shown) associated with the motor (10). The ECS (84) is also provided with a debug/program interface (122) to allow software bug fixes and programming of the ECS (84). This programming port allows the test engineer to fine tune the controller functions to fit the specific engine, initiator, gas mixture or other variation that will be needed as new instances are created and once complete to store that program for future use. This provides a very large economy of use on the manufacturer.

[0033] As shown in FIG. 7, the ECS (84) accomplishes power switching of the controls the four high voltage coils (58), (60), (62) and (64) using insulated gate bipolar transistor (IGBT) devices (124), (126), (128) and (130) comprising 500 to 800 Volts at 10 to 40 Amp 50 KW to 320 KW switches. The ECS (84) accomplishes the power switching of the coils (46), (48) and (50), using metal-oxide-semiconductor field-effect transistor (MOSFET) devices (132), (134), (136) and (138). FIG. 8 shows the ECS (84) schematic of the starter control (140) and refueling control (142). FIG. 8 also shows the ECS (84) schematic for the radio frequency power generator (144) and (146) for the radio frequency generator (52) described above and the radio frequency generator (147) associated with the supplemental cylinder assembly (118). (FIGS. 1-8).

[0034] When it is desired to operate the motor (10), the expansion chamber (24) is evacuated and the ECS (84) is programmed using the debug/program interface (122) to operate as follows: The ECS (84) actuates the valve (78) to dose the expansion chamber (24) with fuel until the pressure within the expansion chamber (24) is approximately one atmosphere. The fuel may be any desired combination of the noble gases: helium (He), neon (Ne), argon (Ar), krypton (Kr), xenon (Xe), and radon (Rn). One fuel mixture known in the art is a combination by volume of 35.6% helium, 26.2% neon, 16.9% argon, 12.7% krypton and 8.5% xenon. While radon may be used, it is inherently unstable and may cause an undesirably large release of energy. Similarly, hydrogen may be used in the mixture if it is desired to speed up the reaction or generate additional power as may be the case with larger displacement engines.

[0035] After dosing the expansion chamber (24) with fuel, the ECS (84) actuates the electric motor (110) coupled to the flywheel (40) to turn the crankshaft (36) and drive the connecting rod (34) and piston (22) until the motor (10) begins to operate under its own power. While the electric motor (110) is engaged, the ECS (84) monitors the crankshaft sensor (82) to determine when the piston (22) is at TDC and start the excitation cycle while applying a recharge cycle to the supplemental cylinder assembly (118) as it returns from bottom dead center (BDC) toward TDC.

[0036] The ECS (84) begins the excitation cycle by supplying the variable or "speed" voltage to the supplemental, cylinder and transition coils (46), (48) and (50) creating an electro magnetic field, so that the north pole of the electro magnet over the cylinder (14) is on the same end as the high voltage electrodes (68), (70), (72) and (74). The change in

voltage to these coils (46), (48) and (50) "squeezes" the fuel within the cylinder (14), compressing the fuel mixture within the cylinder (14) to the center and presetting the ionic form of the lighter gases. By varying the voltage supplied to the coils (46), (48) and (50) the ECS (84) controls the speed at which the motor (10) operates. Increasing the voltage packs the fuel more tightly, increasing the eventual rate of transition of the plasma fuel and with it the linear movement of the piston (22) toward BDC, which the connecting rod (34) translates into increase speed of rotation of the crankshaft (36).

[0037] As the piston reaches ~5 degrees from TDC, the ECS (84) actuates the four high voltage coils (58), (60), (62) and (64), initiating a simple high voltage, 100 KV, arc within the expansion chamber (24). At the same time, the ECS (84) initiates the addition of 2.05 to 47.12 MHz radio frequency (RF) energy into the expansion chamber (24) by providing the radio frequency generator (52) with 12 volts at 8.2 amps (~100 W) to introduce RF energy into the expansion chamber (24) via the high frequency antenna (54).

[0038] As the piston reaches ~45 degrees past TDC, the ECS (84) increases or decreases the voltage applied to the coil (48) as desired to either speed up or slow down the reaction within the cylinder. The specific expansion coefficient is a variant of the gas mixture. Expansion for the fuel mixture listed above is about five times its original volume.

[0039] The heavier elements in the fuel will not be a part of this reaction as the excitation is removed before it has time for them to be effected. The heavier elements act as a buffer between the plasma, the piston and cylinder wall, allowing a targeted push on the piston by the Plasmic transition. The heavier elements are in the mix as a buffer to isolate the plasma from anything that could disrupt the transformation. For example, if the plasma was to touch the interior of the cylinder (14), it would lose the ongoing ability to expand and would immediately retract, so the buffering is important.

[0040] The ECS (84) also supplies a recharge voltage to the supplemental cylinder coil assembly (118) to help regenerate the fuel into gas to get it recombined and ready. As the fuel converts back to gas, it shrinks to form a partial vacuum within the chamber as it returns to one atmosphere and the squeeze provides quicker return to a stable state.

[0041] As soon as the sensor (80) indicates to the ECS (84) that ignition has occurred, the ECS (84) disables voltage to the four high voltage coils (58), (60), (62) and (64) as the transformation to a plasma has started. As soon as the sensor (80) notes that the power has decreased by 50%, the ECS (84) disables voltage to the radio frequency generator (52). The power and wavelength of the RF energy within the transition chamber (25) also dictates the speed of operation of the motor (100). The higher the frequency, the faster the ionization process takes place and the faster the motor (10) operates. The piston should be just over half way down toward BDC Bottom Dead Center) at this time.

[0042] The Transition cycle is allowed to start its collapse, which actually takes place and completes just before BDC. At or about BDC, the ECS (84) removes the speed voltage from the coil (50) and places a recharge voltage on the coils (46), (48) and (50), if needed, for collapse. As the piston (22) begins to move back upward toward TDC, the ECS (84) recognizes the upward speed of the piston (22) which allows the ECS (84) to adjust voltages and duration to either speed up or slow down the motor (10).

[0043] The ECS (84) keys off of signals produced by the sensor (80), comprising at least one for TDC, and may include

multiple pulses to further locate the piston (22) position within the 360 degree rotational cycle of a single power cycle. This input is then translated into internal processor signals to energize the three coils (46), (48) and (50), radio frequency generator (52) and four high voltage electrodes (68), (70), (72) and (74) to function at their proper time in relation to the placement of the piston (22) within cylinder (14) and the 360 degree arc of the crankshaft (36) as set by a predetermined set of parameters. If, at any point the ECS (84) detects a decrease in energy output of the motor, the ECS (84) triggers the valve (78) to provide additional fuel into the expansion chamber (24) through the refueling port (76).

[0044] Although the invention has been described with respect to a preferred embodiment thereof, it is to be understood that it is not to be so limited since changes and modifications can be made therein which are within the full, intended scope of this invention as defined by the appended claims. As an example, the motor may be provided with four, five or more coils which the ECS (84) can switch in sequence. In another example, the ECS (84) may be coupled to device, such as generator, water or air pump etc., to automatically adjust the output of the motor (10) according to the changing demands of the device. In yet another example, the RF power may be increased to 900 MHz to 1.7 GHz, or higher. As the RF frequency goes up, the power required to excite the fuel goes down. The ECS has the ability to sense and react to the engine and it can be programmed to control engines of any design, so any static timing given is for instructional purposes as a starting point for fine tuning.

What is claimed is:

1. An internal expansion engine comprising:
 - (a) an transition chamber;
 - (b) a piston forming a wall of said transition chamber;
 - (c) a charge of a noble gas provided within said transition chamber;
 - (d) wherein said noble gas constitutes at least ten percent of all gases provided within said transition chamber;
 - (e) a magnetic field generator provided around said transition chamber;
 - (f) a radio frequency power source coupled to said transition chamber; and
 - (g) an initiator system located within said transition chamber to initiate the transition process.
2. The internal expansion engine of claim 1, further comprising a connecting rod coupled to said piston.
3. The internal expansion engine of claim 2, further comprising a crankshaft coupled to said connecting rod.
4. The internal expansion engine of claim 3, further comprising a flywheel coupled to said crank shaft.
5. The internal expansion engine of claim 4, wherein said radio frequency power source comprises an antenna extending into said transition chamber.
6. The internal expansion engine of claim 1, wherein said radio frequency power source comprises an antenna extending into said transition chamber.
7. The internal expansion engine of claim 1, wherein said noble gas charge comprises at least twenty percent of all gases provided within said transition chamber.

8. The internal expansion engine of claim 1, wherein said initiator system is a spark coil.

9. The internal expansion engine of claim 1, wherein said noble gas charge comprises at least fifty percent of all gases provided within said transition chamber.

10. The internal expansion engine of claim 1, wherein said transition chamber is toroidal.

11. The internal expansion engine of claim 10, further comprising:

- (a) a connecting rod coupled to said piston;
- (b) a crank shaft coupled to said crank arm;
- (c) a flywheel coupled to said crank shaft; and
- (d) a magnet coupled to said flywheel; and
- (e) a Hall effect switch secured within the magnetic field generated by said magnet.

12. The internal expansion engine of claim 11, further comprising a field effect transistor coupled to said hall effect switch.

13. The internal expansion engine of claim 1, further comprising a field effect transistor switch coupled to said magnetic field generator.

14. The internal expansion engine of claim 1, further comprising a battery coupled to said magnetic field generator.

15. An electronic control system comprising:

- (a) a cylinder coil;
- (b) a first switch coupled to said cylinder coil;
- (c) an initiator system;
- (d) a second switch coupled to said initiator system;
- (e) a radio frequency generator;
- (f) a third switch coupled to said radio frequency generator; and
- (g) a central processing unit coupled to said first switch, said second switch and said third switch.

16. The internal expansion engine of claim 15, wherein said initiator system is a spark coil.

17. A method for moving a piston comprising:

- (a) an expansion chamber;
- (b) a piston forming a wall of said expansion chamber;
- (c) providing a change of noble gas within said expansion chamber;
- (d) generating a magnetic field around said piston;
- (e) generating a plasma within said expansion chamber; and
- (f) generating a spark within said expansion chamber.

18. The method of moving a piston of claim 17, further comprising varying the strength of said magnetic field in response to movement of said piston.

19. The method of moving a piston of claim 17, further comprising increasing said magnetic field as said piston decreases the size of said expansion chamber and decreasing said magnetic field as said piston increases the size of said expansion chamber.

20. The method of moving a piston of claim 19, further comprising ionizing said charge of noble gas within said expansion chamber.

* * * * *