

The 'Hotsabi' Booster

Here are the full step-by-step instructions for making a very simple single-cell booster design from "HoTsAbI" - a member of the Yahoo 'watercar' forum Group. This is a very neat and simple electrolysis booster unit which has raised the average mpg from 18 to 27 (50% increase) on his 1992 5-litre Chevy Caprice.



Caution: This is not a toy. If you make and use one of these, you do so entirely at your own risk. Neither the designer of the booster, the author of this document or the provider of the internet display are in any way liable should you suffer any loss or damage through your own actions. While it is believed to be entirely safe to make and use a booster of this design, provided that the safety instructions shown below are followed, it is stressed that the responsibility is yours and yours alone.

The unit draws only 15 amps which is easily handled by the existing alternator. The construction uses ABS plastic with Sodium Hydroxide ("Red Devil" lye, 1 teaspoon to 8 litres of distilled water) and the gas-mix is fed directly into the air intake filter of the car engine. The electrodes are stainless steel with the negative electrode forming a cylinder around the positive electrode.

The circuit is wired so that it is only powered up when the car ignition switch is closed. A relay feeds power to the electrolyser which is three inches (75 mm) in diameter and about 10 inches (250 mm) tall. The electrolyser circuit is protected by a 30-amp circuit breaker. The electrolyser has several stainless steel wire mesh screens above the water surface.

The output of the electrolyser is fed to a steam trap, also fitted with several stainless steel wire mesh screens, and then on via a one-way valve into a safety bubbler. The bubbler also has stainless steel wire mesh screens which the gas has to pass through before it exits the bubbler. The gas is then passed through an air-compressor style water trap to remove any remaining moisture, and is injected into the air intake of the vehicle. Although not shown in the diagram, the containers are protected by pop-out fittings which provide extra protection in the extremely unlikely event of any of the small volumes of gas being ignited by any means whatsoever.

The ammeter is used to indicate when water should be added to the electrolyser, which is typically, after about 80 hours of driving and is done through a plastic screw cap on the top of the electrolyser cap (shown clearly in the first photograph). This unit used to be available commercially but the designer is now too busy to make them up, so he has generously published the plans free as shown here:

Please read all of these instructions carefully and completely before starting your project. This

project is the construction of an electrolyzer unit which is intended to improve the running of a vehicle by adding gases produced by the electrolysis of water, to the air drawn into the engine when running. There is no magic about this. The 'hydroxy' gas produced by the electrolysis acts as an igniter for the normal fuel used by the vehicle. This produces a much better burn quality, extracting extra energy from the normal fuel, giving better pulling power, smoother running, cooler engine operation, the cleaning out of old carbon deposits inside the engine and generally extending the engine life.

ELECTROLYZER PARTS LIST

1. One 7" long x 3" ABS tubing cut square - de-burr edges
2. One 3" ABS (Acrylonitrile Butadiene Styrene) Plug - clean out threaded cap
3. One Threaded adaptor DWV 3" HXFPT ("DWV" and "HXFPT" are male and female threaded sewer type plastic caps)
4. One 3" ABS cap
5. One 4" Stainless steel cap screw 1/4 20
6. Two stainless steel 1" 1/4 20 cap screw
7. One 10/32 x 1/4" stainless steel screw
8. Five washers and Eight stainless steel nuts 1/4 20
9. One piece of stainless steel shimstock 11" x 6" 0.003" thick
10. One piece of stainless steel 14 gauge wire mesh 8" x 3"
11. One 3/8" nylon plug
12. One 1/4" x 1/4" NPT (National Pipe Tap) barbed fitting
13. Plumbers tape

TOOLS LIST

1. Hand drill
2. Cutters (for mesh and shimstock)
3. 1/4" NPT tap and 5/16" drill bit
4. 3/8" NPT tap and 1/2" drill bit
5. 10/32" tap and 1/8" drill bit
6. Clamp and 1" x 1" wood strip
7. Hex key "T-handle" wrench to fit capscrew
8. Philips screwdriver
9. Small adjustable wrench



Cut and fit shimstock into ABS tubing, 11" works well as this gives a 1" overlap.

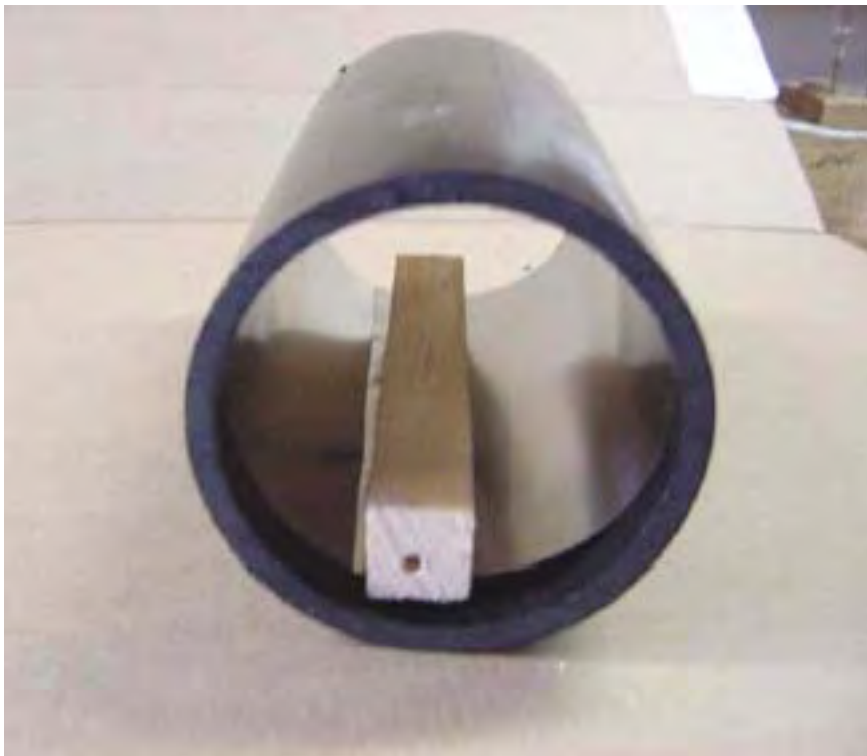

For drilling, use a strip of wood.
Be sure shimstock is flush with at least one edge of the tube.
Use the flush edge as the bottom of the electrolyzer.



Clamp securely and drill two 0.165" holes, one on either side, perpendicular to each other, as best you can. These holes will be tapped 1/4" 20

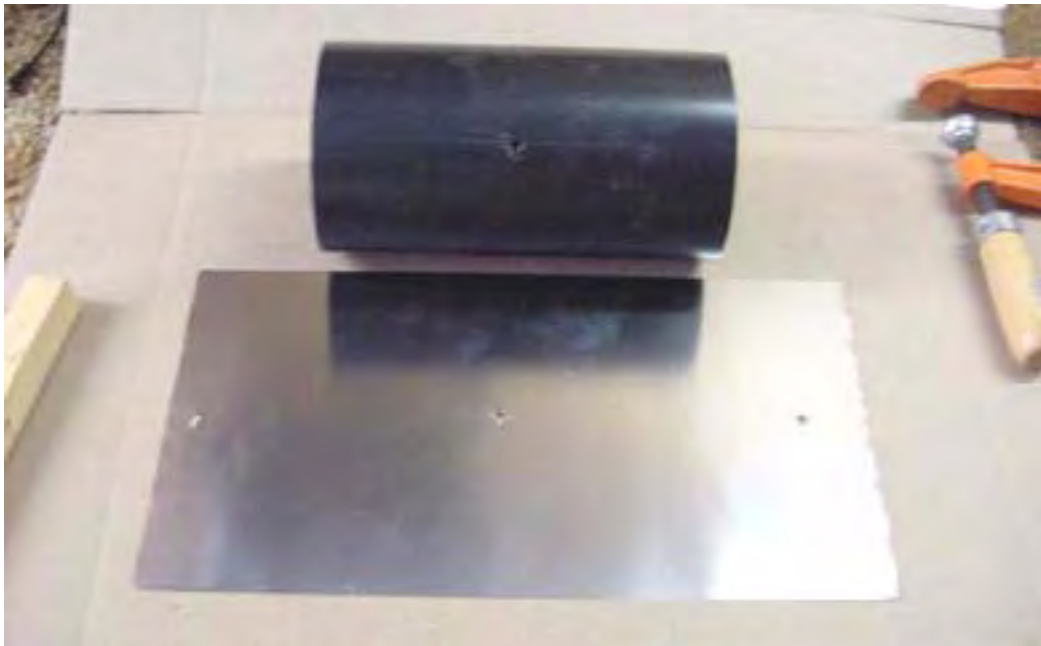

The shimstock holes need to be reamed to accept the capscrew.

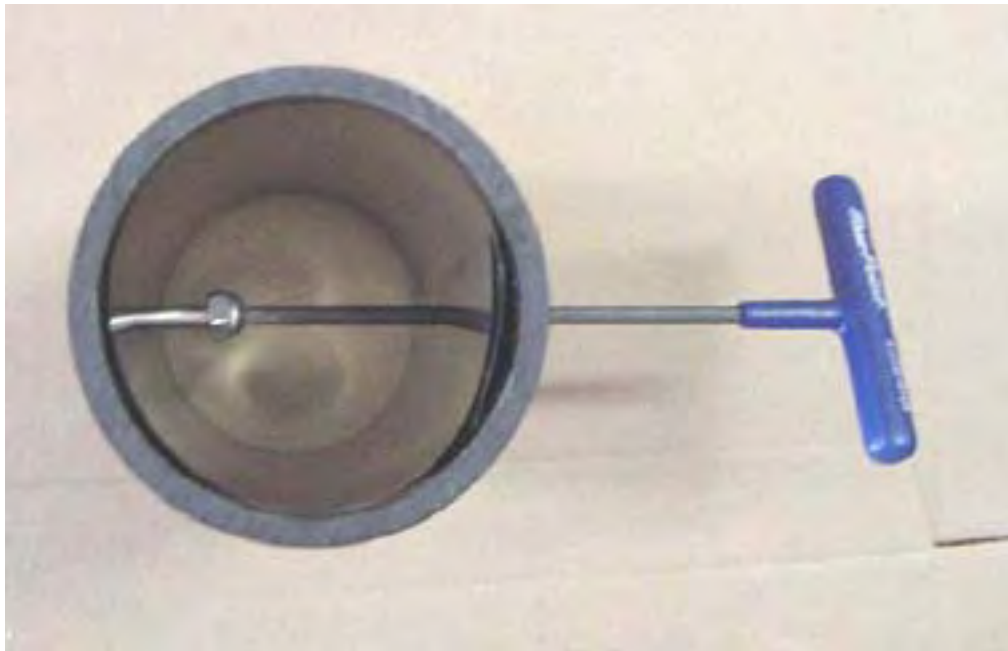

Note: This is why 2 holes are drilled (to facilitate assembly)
Next, attach the electrode inside the barrel.
It is **important** to us a stainless steel nut inside to seat the capscrew.



Note that the shimstock is flush with the bottom of the tube.
Final assembly for the electrodes. Note that the capscrews each have stainless steel nuts inside the barrel to seat to the shimstock.
The screw on the left will be used as the Negative battery connection to the cell while the screw on the right merely seats the shimstock.



The upper component is Threaded adaptor DWV 3" HXFPT

The lower component is 3" ABS Plug, clean out threaded cap.

Prepare the top cap and plug:

Drill and tap a 3/8" NPT in the centre of the threaded cap (main filling plug)

Drill and tap a 1/4" NPT on the side (barbed fitting).



Prepare the bottom cap:
Drill and tap 1/4" 20 hole in the centre.
Install capscrew with stainless steel nut. Tighten and install washer and stainless steel nut outside.



This is the Positive battery connection.



This is the finished e-cell shown here upside down.
Assemble the unit using ABS glue.

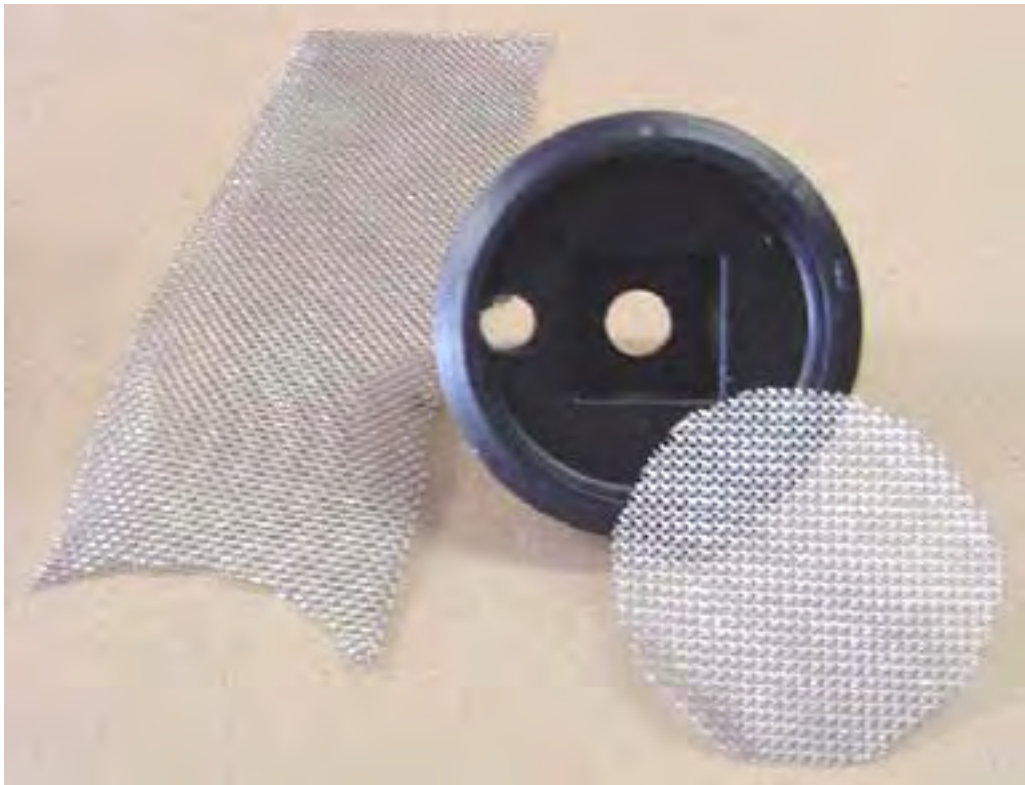

Next, prepare the stainless steel mesh. Cut it carefully to fit inside the threaded cap. Use at least 3 pieces.



After fitting the mesh tightly into the cap, mount it with a 10/32 stainless steel screw on the opposite side to the 1/4" tapped hole for the barbed fitting. This is a flame arrestor, so make CERTAIN that the entire inside is covered tightly. Note that the sides wrap up. Turn each layer to cross the grain of the mesh.



Use white "plumber's tape" on all threaded fittings.

This unit has raised the average mpg on my 1992 5-litre Chevy Caprice from 18 to 27 mpg which is a 50% increase. It allows a very neat, professional-looking installation which works very well:

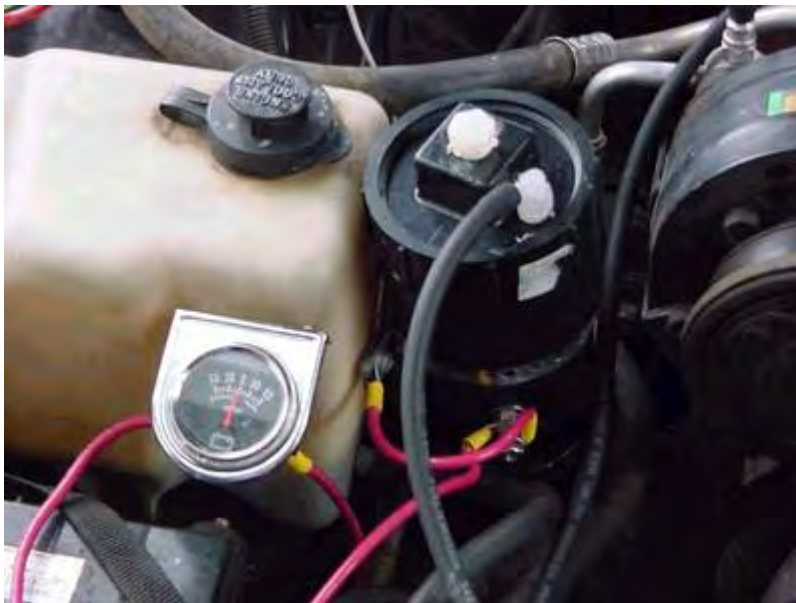



The unit draws only 15 amps which is easily handled by the existing alternator. The construction uses ABS plastic with Sodium Hydroxide (“Red Devil” lye, 1 teaspoon to 8 litres of distilled water) and the gas-mix is fed directly into the air intake filter of the car engine. The electrodes are stainless steel with the negative electrode forming a cylinder around the positive electrode:

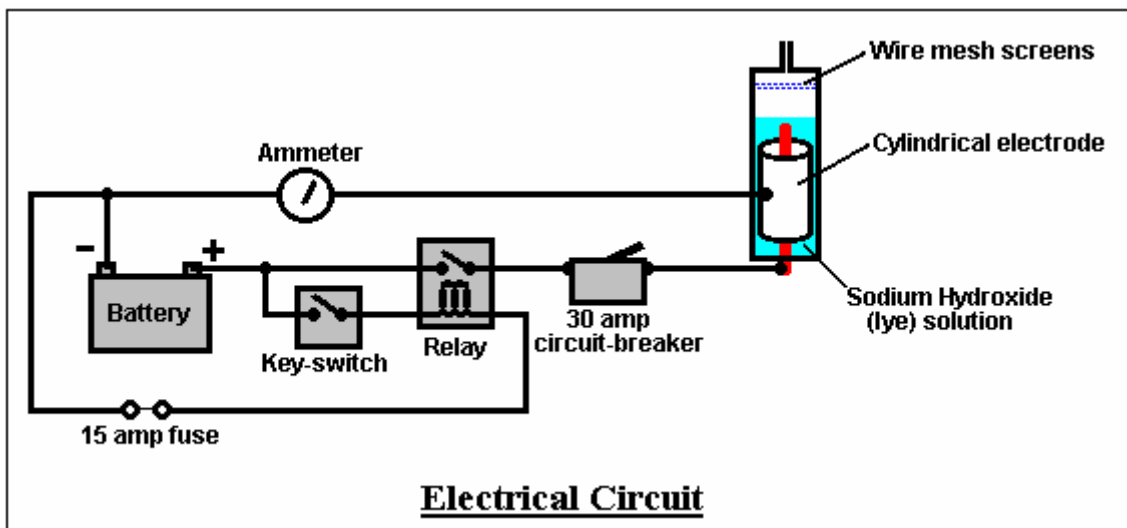

The circuit is wired so that it is only powered up when the car ignition switch is closed. A relay feeds power to the electrolyser which is three inches (75 mm) in diameter and about 10 inches (250 mm) tall. The electrolyser circuit is protected by a 30-amp circuit breaker. The electrolyser has several stainless steel wire mesh screens above the water surface.

The output of the electrolyser is fed to a steam trap, fitted with several stainless steel wire mesh screens, and then on via a one-way valve into a safety bubbler:

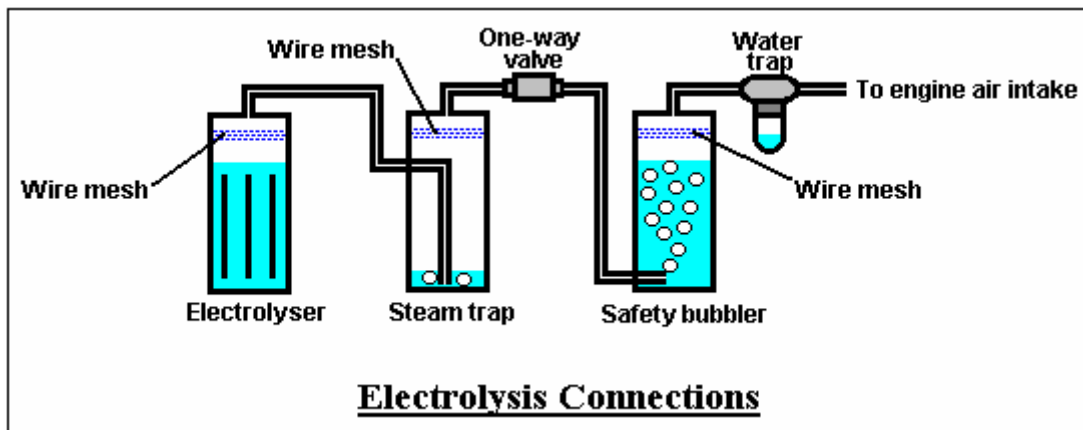

The bubbler also has stainless steel wire mesh screens which the gas has to pass through before it exits the bubbler. The gas is then passed through a compressor-style water trap to remove any remaining moisture, and is injected into the air intake of the vehicle. Although not shown in the diagram, the containers are protected by pop-out fittings which provide extra protection in the extremely unlikely event of any of the small volumes of gas being ignited by any means whatsoever.

The ammeter is used to indicate when water should be added to the electrolyser, which is typically, after about 80 hours of driving and is done through the plastic screw cap on the top of the electrolyser cap.

All of the 3/8" plastic fittings including one way valves, come from Ryanherco and are made of Kynar to withstand heat. The water trap is from an air compressor. The 3/16" tubing or hose is also high-heat type from an automatic transmission coolant lines. I use Direct Current and limited with a thermal breaker and LYE mixture adjustment

Booster Contact: hotsabi@gmail.com (please put "e-cell" in the title of the e-mail).

(c) Copyright 2005. All rights reserved

Comments by Patrick Kelly:

This design is very simple to construct, but as it is just a single cell with the whole of the vehicle's voltage placed across it, a good deal of the electrical power goes in heating the electrolyte rather than making the wanted hydroxy gas.

If there is sufficient space to fit two in, then using two allows you use half the current and that halves the heat generated in the units and doubles the length of time between topping up the unit with water:

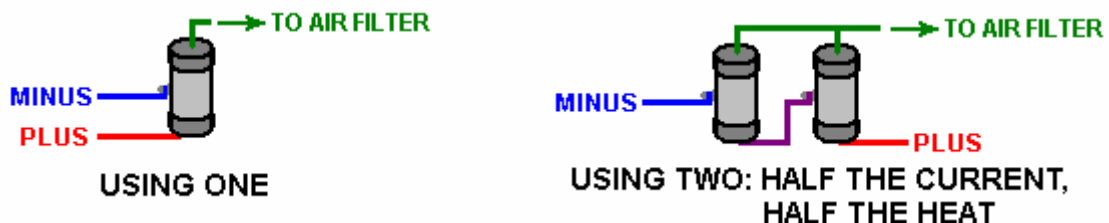

Please don't get the impression that if a small amount of hydroxy gas produces a very beneficial effect on the running of a vehicle, that adding much more hydroxy gas will give even better results, as that is not the case. Each vehicle is different and will have a different optimum flow rate of hydroxy gas and if that optimum rate is exceeded, then although the mpg improvement may actually be reduced rather than increased. If in doubt, start with a low current (with more dilute electrolyte) which will produce less gas and see what the mpg results are. Then try a slightly stronger mix and check the mpg over several gallons of fuel. This will allow you to

determine the booster current at which your particular vehicle operates best. This is not a competition to see who can produce the highest gas output, instead, it is a process to find out what the highest mpg your vehicle can give when using this simple booster design.

Mixing the electrolyte: Please remember that the sodium hydroxide or 'lye' (Lowes store: Roebic 'Heavy Duty' Crystal Drain Opener) is a strongly caustic substance which needs to be treated with care.

Always store it in a sturdy air-tight container which is clearly labelled "DANGER! - Sodium Hydroxide". Keep the container in a safe place, where it can't be reached by children, pets or people who won't take any notice of the label. If your supply of sodium hydroxide is in a strong plastic bag, then once you open the bag, you should transfer all its contents to a sturdy, air-tight, plastic storage container, which you can open and close without risking spilling the contents. Hardware stores sell plastic buckets with air tight lids that can be used for this purpose.

When working with dry flakes or granules, wear safety goggles, rubber gloves, a long sleeved shirt, socks and long trousers. Also, don't wear your favourite clothes when handling hydroxy solution as it is not the best thing to get on clothes. It is also good practice to wear a face mask which covers your mouth and nose. If you are mixing solid sodium hydroxide with water, always add the hydroxide to the water, and not the other way round, and use a plastic container for the mixing, preferably one which has double the capacity of the finished mixture. The mixing should be done in a well-ventilated area which is not draughty as air currents can blow the dry hydroxide around.

When mixing the electrolyte, **never** use warm water. The water should be cool because the chemical reaction between the water and the hydroxide generates a good deal of heat. If possible, place the mixing container in a larger container filled with cold water, as that will help to keep the temperature down, and if your mixture should "boil over" it will contain the spillage. Add only a small amount of hydroxide at a time, stirring continuously, and if you stop stirring for any reason, put the lids back on all containers.

If, in spite of all precautions, you get some hydroxide solution on your skin, wash it off with plenty of running cold water and apply some vinegar to the skin. Vinegar is acidic, and will help balance out the alkalinity of the hydroxide. You can use lemon juice if you don't have vinegar to hand - but it is always recommended to keep a bottle of vinegar handy.

Patrick Kelly
engpjk@yahoo.co.uk
<http://www.free-energy-info.co.uk>
<http://www.free-energy-info.com>