

## ***WE LIVE IN A MASSIVE ENERGY FIELD***

**MOST PEOPLE ARE NOT AWARE OF THE FACT, BUT WE LIVE IN A MASSIVE, INEXHAUSTIBLE ENERGY FIELD :**

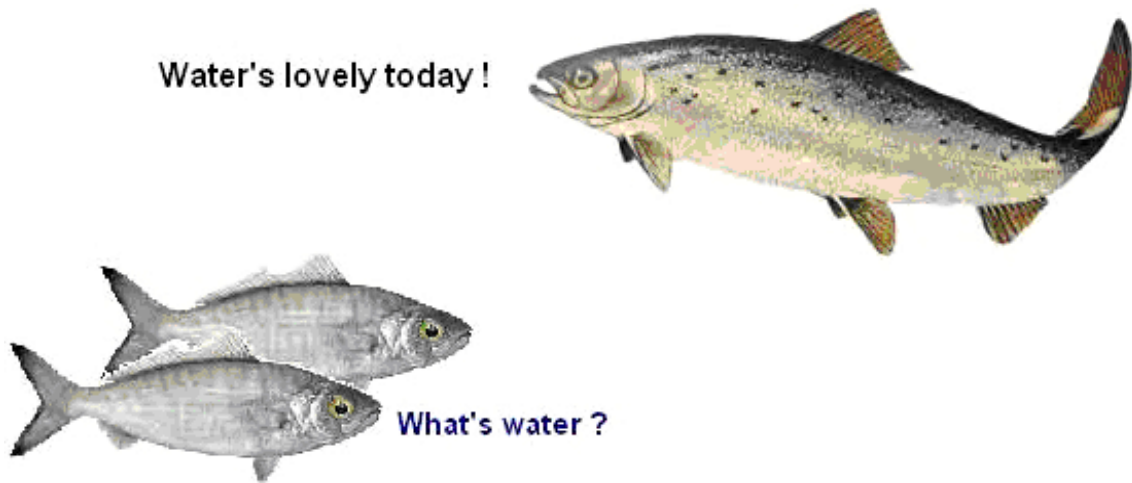

**IT'S SUPPOSED TO BE A JOKE, ALTHOUGH IT IS NOT FUNNY FOR US HUMANS WHO ARE IN THE SAME CONDITION, BUT TWO SMALL FISH ARE SWIMMING ALONG WHEN A BIGGER FISH PASSES THEM AND REMARKS "THE WATER IS LOVELY TODAY ISN'T IT" AND THEN ONE OF THE SMALL FISH ASKS THE OTHER "WHAT'S WATER?". THAT IS SUPPOSED TO BE FUNNY BECAUSE THE FISH ASKING THE QUESTION IS COMPLETELY IMMERSSED IN WATER AND COULDN'T SURVIVE WITHOUT IT. THE HUMOUR DISAPPEARS IMMEDIATELY YOU REALISE THAT MOST PEOPLE ARE IN THE SAME POSITION AND WOULD ASK "WHAT IS THE UNIVERSAL ENERGY FIELD?" EVEN THOUGH THEY ARE IMMERSSED IN IT AND COULDN'T SURVIVE WITHOUT IT.**

**BECAUSE OF THIS SEVERE LACK OF KNOWLEDGE, WE MISS OUT EVERY DAY OF OUR LIVES, WE DO NOT ACCEPT WHAT IS BEING OFFERED TO US AS A FREE GIFT. FOR EXAMPLE, WE CAN GROW FRUIT AND VEGETABLES, BUT WITHOUT EXPENDING ANY MAJOR EFFORT WE COULD EASILY HAVE MUCH GREATER RESULTS WITH SIX CROPS PER YEAR AND EACH CROP BEING FOUR TIMES LARGER. HOW? WITH A LARGE GREENHOUSE LIKE THIS :**



**THIS STRUCTURE WAS BUILT IN CANADA BY LES BROWN AND IT PRODUCED FOOD FOR HIM CONTINUOUSLY IN SPITE OF THE BITTER CANADIAN WINTERS. THE STRUCTURE IS A PYRAMID.**

LES BROWN EXPERIMENTED EXTENSIVELY WITH PYRAMIDS AND RELATED DEVICES. IT SHOULD BE STRESSED AT THIS POINT THAT VARIOUS FACTS HAVE BEEN OBSERVED, AT THIS TIME THE EFFECT CAUSED BY A PYRAMID IS NOT FULLY UNDERSTOOD, AND NO "LAWS" YET BEEN DEDUCED. WE HAVE TO WORK ON THE BASIS OF "THIS IS WAS DONE, AND THESE ARE THE RESULTS". BECAUSE OF THIS, THE FOLLOWING EXTRACT FROM THE WORK OF THE LATE LES BROWN IS REPRODUCED HERE AND YOU MUST DECIDE FOR YOURSELF IF WHAT SAYS IS TRUE AND WHETHER OR NOT IT MIGHT BE WORTH YOUR TRYING OUT SOME OF WHAT HE SAYS :



WHILE  
HAVE  
WHAT  
HE  
WHILE

IN CONDUCTING PYRAMID EXPERIMENTS, YOU SHOULD LOOK DAILY FOR SIGNS OF CHANGE AND NOTE THEM METICULOUSLY, AND ABOVE ALL BE PATIENT. DON'T PLANT A SEED ONE DAY AND EXPECT TO HAVE A PLANT SIX FEET TALL THE VERY NEXT DAY. A PLANT TAKES JUST AS LONG TO DEVELOP INSIDE A PYRAMID AS IT DOES OUTSIDE, BUT IN TIME YOU WILL SEE THE TREMENDOUS DIFFERENCE IN SIZE. ALSO, DON'T KEEP MOVING PLANTS AROUND INSIDE YOUR PYRAMID DURING AN EXPERIMENT – LEAVE POTS STATIONARY SO THAT YOU CAN SEE WHAT THE RESULTS ARE.

YOU CAN MAKE YOUR OWN PYRAMIDS. THEY CAN BE CONSTRUCTED ENTIRELY FROM INEXPENSIVE MATERIALS. CARDBOARD, WIRE, PLYWOOD OR ANYTHING RIGID ENOUGH TO RETAIN THE PYRAMID SHAPE WILL DO. THE PYRAMID DOES NOT NECESSARILY HAVE TO BE SOLID – IN EXPERIMENTS, JUST THE OUTLINE SHAPE IS SUFFICIENT PROVIDED THAT IT IS JOINED AT ALL CORNERS AND AT THE APEX.

REMEMBER THAT WITH ALL TYPES OF PYRAMID, POSITIONING IS ALL IMPORTANT. ONE OF THE SQUARE BASE SIDES MUST POINT TOWARDS MAGNETIC NORTH. USE A COMPASS TO DETERMINE THE DIRECTION OF MAGNETIC NORTH. SEVERAL PYRAMIDS CORRECTLY ORIENTATED AND STACKED ON TOP OF ONE ANOTHER WILL PRODUCE INCREASED ENERGY, CELL ACTIVITY AND GROWTH.

USING PYRAMIDS, I SINCERELY BELIEVE THAT I CAN GROW 36 TIMES MORE AND BETTER PLANTS IN A GIVEN AREA THAN ANY FARMER OR MARKET GARDENER CAN IN THE SAME AREA USING CONVENTIONAL METHODS.

WHEN ALL FOUR SIDES ARE PUT TOGETHER, YOU MUST HAVE A PYRAMID WHICH IS LEANING IN AT 51 DEGREES, 51 MINUTES, 14 SECONDS. IF YOU GROW A PLANT INSIDE A PYRAMID, IT ABSORBS ENERGY AT A HIGH INTENSITY AND SO THE RESULT IS ENORMOUS GROWTH. WHEN THIS IS APPLIED TO VEGETABLES AND FRUIT, THE PLANTS AS WELL AS THEIR PRODUCTS ARE IMMENSELY OVERSIZED. MY OWN EXPERIMENTS HAVE CONVINCED ME THAT THIS ENERGY CREATES A SPECIAL REACTION IN THE LIVING CELLS OF PLANTS, RESULTING IN LARGER BLOOMS, LEAVES AND FRUITS ON WHATEVER PLANTS ARE PROPAGATED WITHIN THE PYRAMID.

THE NORMAL LIFE CYCLE OF LETTUCE, FOR INSTANCE, FROM SEED TO MATURITY, IS SIX TO EIGHT WEEKS. GROWN UNDER A PYRAMID, THE LIFE CYCLE IS STILL THE SAME BUT THE PLANT IS CONSIDERABLY LARGER. IF YOU ALLOW THE VINE TYPE OF TOMATO TO MATURE TO SIX OR SEVEN TRUSSES UNDER A PYRAMID WHILE SIMULTANEOUSLY ALLOWING AN IDENTICAL PLANT TO DO THE SAME OUTSIDE THE PYRAMID, GIVING BOTH OF THE PLANTS THE SAME FEEDING AND WATERING, A STARTLING DIFFERENCE IN YIELD OCCURS. I SHOULD MENTION THAT IF YOU PUT YOUR OUTSIDE PLANT TOO NEAR THE PYRAMID, IT WILL REACH FOR, AND RECEIVE, SOME OF THE PYRAMID'S ENERGY, SO KEEP IT WELL AWAY TO GET A FAIR COMPARISON. THE OUTSIDE TOMATOES WOULD WEIGH OUT AT APPROXIMATELY 10 TO 14 POUNDS PER PLANT, WHILE THE PLANT GROWN IN THE PYRAMID WOULD PRODUCE BETWEEN 50 AND 60 POUNDS OF TOMATOES. NOT EVERY TYPE OF PLANT GROWN UNDER A PYRAMID WILL PRODUCE THIS INCREASE; THIS IS THE AVERAGE WHICH I HAVE COME TO EXPECT FROM TOMATOES.

A FEW MORE AVERAGES WHICH I HAVE OBTAINED REPEATEDLY WERE: LETTUCE TWO TO THREE TIMES LARGER THAN AVERAGE; BEANS 25 INCHES LONG BY 1.25 INCHES WIDE; CABBAGE – WHEN

CONTROLS WERE 3 POUNDS EACH, THE PYRAMID GROWN PLANTS WERE 12 TO 13 POUNDS PER HEAD; RADISHES THAT NORMALLY WOULD BE THE SIZE OF A QUARTER WERE FOUR INCHES IN DIAMETER, CONTROL CUCUMBERS THAT AVERAGED 14 INCHES IN LENGTH AND WEIGHED UP TO ONE POUND NORMALLY, WERE 21 INCHES LONG AND WEIGHED UP TO FOUR POUNDS WHEN GROWN IN A PYRAMID.

ENERGISED AIR IN THE PYRAMID ALSO APPEARS TO REPEL SMALL INSECTS, SO THERE IS NO NEED TO USE PESTICIDES WITHIN ITS GLASS WALLS. PEST-FREE PLANTS GROW TO MATURITY INSIDE, WITH NONE OF THE SETBACKS PLANTS SUBJECT TO NORMAL ATTACK FROM PESTS SUFFER IN THE GARDEN OUTSIDE. THIS ALSO MEANS THAT PYRAMID-GROWN VEGETABLES NEED NO WASHING UPON HARVESTING. THE MERE APPEARANCE OF SUCH PLANTS IS MORE APPETISING THAN THAT OF THOSE GROWN NORMALLY. GREENS ARE MORE VIVID AND MANY LEAVES HAVE A SHEEN WHICH IS NOTICEABLY ABSENT FROM PLANTS IN KITCHEN GARDENS.

AN EGG BROKEN OUT OF ITS SHELL AND LEFT INSIDE A PYRAMID WILL GRADUALLY CONGEAL AND BECOME LIKE PLASTIC AS THE PYRAMID ENERGY WORKS ON IT'S CELLS – HARMLESSLY. THE CELLS DO NOT DIE OR SPOIL. AFTER A PERIOD OF WEEKS OR MONTHS, THESE CONGEALED EGGS CAN BE RECONSTITUTED IN WATER TO THE POINT WHERE THEY CAN BE EATEN WITH COMPLETE SAFETY, AND THEY TASTE EVEN MORE DELICIOUS THAN EGGS PREPARED IN THE USUAL WAY.

ONE PECULIAR PHENOMENON WHICH I HAVE OBSERVED UNDER MY LARGE PYRAMID IS THE FORMATION OF DEW ON THE PLANTS INSIDE IT. THIS HAPPENS EARLY IN THE MORNING. DURING ALL MY YEARS OF EXPERIENCE WITH GREENHOUSES, I NEVER NOTICED DEW FORMING ON ANY PLANTS IN CONVENTIONAL GREENHOUSES. THIS DEW DISSIPATES GENTLY AS THE SUN GROWS STRONGER, EXACTLY AS IT WOULD OUTSIDE. ALSO, AFTER A RECENT THUNDERSTORM, MY PYRAMID CUCUMBERS GREW TWO TO TWO AND A HALF INCHES IN A MATTER OF HOURS.

I BUILT A PYRAMID PURELY FOR RESEARCH PURPOSES. FOR LARGE SCALE PRODUCTION, A PYRAMID WHICH IS MUCH GREATER IN SIZE WOULD BE NEEDED. WHEN BUILDING THE PROTOTYPE, I ENCOUNTERED AND OVERCAME VIRTUALLY ALL THE PROBLEMS ONE CAN EXPECT TO MEET IN A CONSTRUCTION OF THIS TYPE. BUILDING A PYRAMID IS NOTHING LIKE BUILDING A HOUSE, AND WHILE A SLIGHT DIFFERENCE IN MEASUREMENT CAN BE OVERCOME WHEN BUILDING A HOUSE, IT IS NOT POSSIBLE TO MAKE A MISTAKE IN A PYRAMID AND JUST CARRY ON BUILDING. THE PARTICULAR PIECE CONTAINING THE ERROR MUST BE PULLED OUT AND REPLACED CORRECTLY, AS ANY MISTAKE IS TRANSFERRED ALL THE WAY AROUND THE PYRAMID.

MY TEST PYRAMID IS 30 FEET HIGH AT THE PEAK. THE SIDES FROM BASE CORNER TO PEAK MEASURE 44 FEET 4.5 INCHES WITH A BASE EDGE LENGTH OF 46 FEET 10.5 INCHES. IT CONTAINS TWO ADDITIONAL FLOORS ABOVE THE GROUND LEVEL, AND THE SUM OF THE AREAS OF THESE TWO FLOORS IS EQUAL TO, OR GREATER THAN, THAT OF THE GROUND FLOOR. THUS, THE TWO ADDITIONAL FLOORS VIRTUALLY DOUBLES THE GROWING AREA.

MY FIRST FLOOR IS 12 FEET ABOVE THE GROUND AND THERE IS A REASON FOR THIS. I CALCULATED THAT WHEN THE SUN WAS AT ITS HIGHEST POINT, THE FIRST FLOOR WOULD HAVE TO BE AT 12-FEET HIGH TO ALLOW THE SUN TO SHINE ON TO THE BACK, NORTHERN EDGE OF THE GROUND FLOOR. THE 12-FOOT HEIGHT WAS PERFECT, BUT NOT ABSOLUTELY NECESSARY AS THERE ARE AS MANY PLANTS THAT GROW WELL IN SHADE AS THERE ARE THAT PREFER THE SUN. IN FUTURE, MY PYRAMID FLOORS WILL ALL BE 8 FEET APART AND I WILL PUT MY SUN-LOVING PLANTS IN THE SOUTHERN HALF AND MY SHADE-LOVING PLANTS IN THE BACK, NORTHERN HALF.

BY PLACING THE FLOORS AT EIGHT-FOOT INTERVALS THERE IS MUCH MORE GROWING AREA. WITH FLOORS INSIDE A PYRAMID, THE HIGHER UP THE FLOOR, THE HIGHER THE TEMPERATURE THERE. FOR EXAMPLE, IF THE GROUND FLOOR IS AT 75 DEGREES F. THEN THE SECOND FLOOR

WOULD BE 90 DEGREES F. AND THE THIRD FLOOR WOULD BE ABOUT 105 TO 115 DEGREES F. AND EACH OF THE HIGHER FLOORS WOULD ALSO HAVE HIGHER HUMIDITY. THE GROUND FLOOR IS PERFECT FOR SUCH CROPS AS RADISHES, LETTUCE, CARROTS, BEETS, TOMATOES, ETC. THE SECOND FLOOR IS IDEAL FOR CUCUMBERS, SQUASH, PEPPERS AND PLANTS WHICH LIKE IT HOTTER AND MORE HUMID THAN THE GROUND FLOOR. THE TOP FLOOR CAN BE USED FOR LEMONS, ORANGES, FIGS, AND ESPECIALLY ORCHIDS.

THE PYRAMID DRAWS IN ITS OWN WATER ON THE GROUND FLOOR; I HAVE NEVER HAD TO WATER THAT LEVEL WHICH IS BUILT DIRECTLY ON THE GROUND. IT NEVER DRAWS TOO MUCH OR TOO LITTLE WATER, ALWAYS JUST THE RIGHT AMOUNT FOR GROWTH. NATURALLY, I HAVE TO PUMP WATER TO THE UPPER FLOORS, BUT BECAUSE THE GROUND FLOOR PROVIDES ITS OWN WATER SUPPLY, AT LEAST HALF OF MY PYRAMID IS WATERED AUTOMATICALLY FOR NO COST. I GROW RIGHT IN THE GROUND ON WHICH THE PYRAMID STANDS, BUT UPSTAIRS I HAVE PLACED WOODEN PLANTING TROUGHS ALL AROUND THE FLOORS, LEAVING ROOM TO WALK, AND I GROW PLANTS IN THESE. IT IS A MAJOR JOB GETTING SOIL TO THE UPPER FLOORS INITIALLY, BUT IT IS ONLY A ONE-TIME TASK. THE TROUGHS ARE 14 INCHES WIDE AND 16 INCHES DEEP AND HAVE A BOTTOM.

SPACE IN THE PYRAMID IS USED TO THE UTMOST. AT THE PERIMETER OF THE LOW AREAS I PLANT THE KIND OF PLANTS THAT NEED LITTLE HEADROOM, AND THEN PLANT THE BIGGER CROPS TOWARDS THE MIDDLE. THIS IS A MATTER OF COMMON SENSE, BUT USING VINE TYPE TOMATOES AND STRINGING THEM UP, ONE CAN WORK BETTER BETWEEN THE ROWS, AND IF THE LOWER LEAVES ARE REMOVED, THERE IS SUFFICIENT SPACE TO GROW LETTUCE, CABBAGE OR ANY LOW-LYING CROP IN BETWEEN THE TOMATO PLANTS. THE TRUSSES MAY BE LEFT ON THE TOMATOES AS THEY WILL NOT SHADE THE LOW-LYING PLANTS.

TO ENSURE A STEADY SUPPLY OF FOOD, IT IS WISE TO PLANT ONLY A FEW PLANTS OF EACH VARIETY AT INTERVALS, WHICH MEANS THAT IN THE BEGINNING IT WILL TAKE SEVERAL WEEKS TO REAP A FULL HARVEST, BUT AFTER THAT THERE WILL BE A CONTINUOUS YIELD. BY PLANTING IN SUCH A MANNER, THE GROWER WILL REAP ABOUT SIX FULL CROPS EACH YEAR. THIS METHOD APPLIES ONLY TO AN ENCLOSED PYRAMID, WHICH WOULD ALSO NEED HEATING IN THE WINTER. THE MEANS OF HEATING IS UP TO THE INDIVIDUAL. PERSONALLY, I USE A WOOD-BURNING STOVE BECAUSE I HAVE MY OWN SUPPLY OF WOOD. HOWEVER, A WOOD AND OIL COMBINATION IS BEST BECAUSE IT ALLOWS ONE TO BE AWAY FOR A COUPLE OF DAYS WHEN NECESSARY AND IF THE WOOD FIRE GETS LOW, THEN THE OIL BURNER TAKES OVER.

IN ADDITION TO FOOD GROWTH, THE PYRAMID ALSO HAS APPLICATION IN FOOD PRESERVATION. I HAVE READ STATISTICS WHICH STATE THAT 40% OF ALL FOOD GROWN IN MY HOME COUNTRY OF CANADA IS LOST TO SPOILAGE, WHETHER AT THE PLACE OF STORAGE, IN TRANSPORT, IN WHOLESALE OR RETAIL, OR FINALLY IN THE HOME. REGARDLESS OF HOW THIS SPOILAGE OCCURS, THIS STATE OF AFFAIRS CAN BE REMEDIED. THE ENERGY OF THE PYRAMID WHICH GROWS PLANTS SO AMAZINGLY WELL CAN ALSO BE USED FOR THE MUMMIFICATION OF FOOD, WHICH CAN BE DEHYDRATED AND KEPT IN STORAGE FOR AN INDEFINITE PERIOD WITHOUT LOSING ANY OF IT'S TASTE OR NUTRITIONAL PROPERTIES. THERE ARE ABSOLUTELY NO ILL EFFECTS ON ANY FOOD STORED IN A PYRAMID. IN FACT, IN MANY INSTANCES IT IS FAR BETTER WHEN RECONSTITUTED THAN IT WAS IN THE FIRST PLACE. IT HAS THE WATER TAKEN OUT OF IT, BUT IT ALSO REPELS BACTERIA AND AS A RESULT, NOTHING WILL ROT IN A PYRAMID. FOR INSTANCE, I CANNOT MAKE A COMPOST HEAP INSIDE MY PYRAMID; I HAVE TO DO IT OUTSIDE, OTHERWISE THE INGREDIENTS IN THE COMPOST ALL REMAIN IN GOOD SHAPE AND WILL NOT BREAK DOWN. THE GRAIN GROWN IN MANITOBA TODAY IS A DIRECT DESCENDANT OF THE GRAIN FOUND IN THE GREAT PYRAMID, GRAIN THAT HAD BEEN THERE FOR CENTURIES AND HAD KEPT PERFECTLY.

MY PYRAMID IS MADE FROM ROUGH-SAWN TIMBER (THAT IS, NOT PLANED ALL OVER), TIMBER CUT ON, AND NEAR, MY PROPERTY AND MILLED BY A NEIGHBOUR. BUT IT IS NOT NECESSARY FOR PYRAMIDS TO BE MADE OF WOOD. THEY CAN BE MADE OF ANY RIGID MATERIAL WHICH WILL SUPPORT PERMANENT GLAZING: CARDBOARD, STRONG WIRE, SHEET STEEL OR METAL, ANGLE

**IRONS, LOGS – ANYTHING WHICH WILL NOT CURVE AND WHICH CAN BE MEASURED PRECISELY AND FITTED.**

**PYRAMIDS DO NOT HAVE TO HAVE SOLID FACES. FOR MANY USES, OPEN-SIDED SHAPES WILL DO, SO LONG AS ALL THE CORNERS ARE JOINED AND THE ANGLES ARE CORRECT. MY PRESENT PYRAMID IS MADE OF TIMBER AND COVERED WITH HEAVY-GAUGE PLASTIC SHEET. FUTURE ONES WILL BE SHEATHED IN FIBREGLASS, ACRYLIC OR GLASS. THEY WILL BE CLOSED PYRAMIDS SOLELY BECAUSE I PROPOSE TO GROW FOOD DURING THE DEPTHS OF CANADA'S FRIGID WINTERS. MY PYRAMID FRAME IS BUILT MAINLY OF WOOD MEASURING TWO INCHES BY FOUR INCHES AND TWO INCHES BY EIGHT INCHES ROUGH SAWN. PYRAMIDS CAN BE BUILT ANY SIZE AS LONG AS THE PROPORTIONS ARE CORRECT.**

**THERE IS A VIDEO OF LES BROWN LECTURING ON THE WEB AND IT IS AT :  
<http://www.youtube.com/watch?v=P7VN6B2GjVI>**

**A PYRAMID CAUSES THE UNIVERSAL ENERGY FIELD TO FLOW UP THE EDGES AND THROUGH THE STRUCTURE AND THE EFFECT SPILLS OUT TO PLANTS AROUND THE BASE AS WELL. IT HAS ENORMOUSLY BENEFICIAL EFFECTS ON PLANTS, ANIMALS AND HUMANS.**

**THAT IS ONE WAY TO ACCESS THE UNIVERSAL ENERGY FIELD AND ANOTHER IS TO USE A COIL OF WIRE.**

**BATTERIES ARE CHARGED BY APPLYING A HIGH ENOUGH VOLTAGE TO THEM. BUT THE RATE OF CHARGE IS NOT CONSTANT. IN THE FIRST SPLIT SECOND, THE VERY LIGHT ELECTRONS FROM THE CHARGING SOURCE SPIRAL DOWN THE OUTSIDE OF THE CONNECTING WIRE AT THE SPEED OF LIGHT. WHEN THEY REACH THE BATTERY BEING CHARGED THERE IS A PROBLEM AND THAT IS THE FACT THAT THE CHARGING CURRENT INSIDE THE BATTERY IS CARRIED BY MUCH HEAVIER IONS AND THEY DON'T MOVE AT THE SPEED OF LIGHT :**

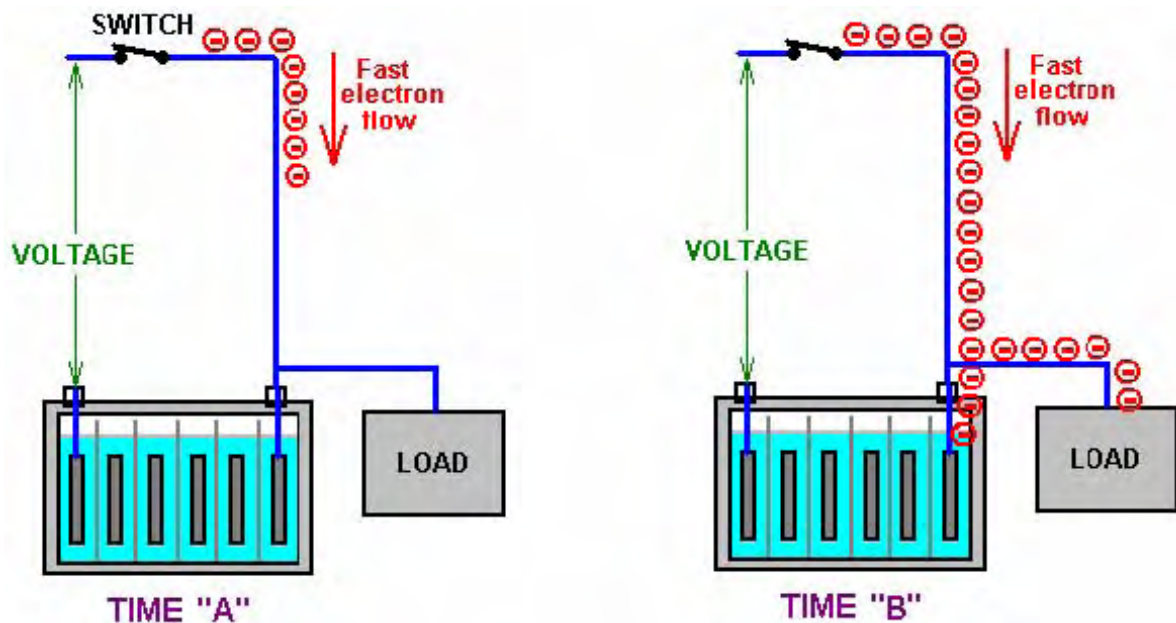

**A TINY FRACTION OF A SECOND AFTER SWITCHING ON, THE ELECTRONS REACH THE BOTTLENECK OF THE HEAVY BATTERY IONS AND SO THEY PILE UP IN A GREAT CLUSTER :**

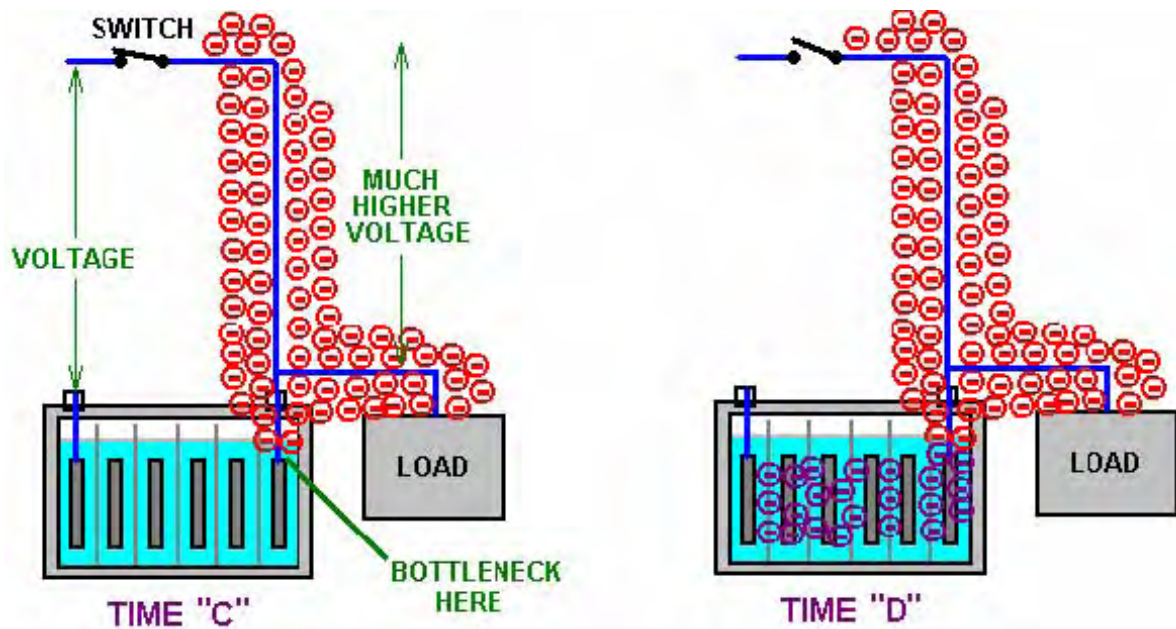

THIS HAS THE SAME EFFECT AS IF A MUCH HIGHER VOLTAGE SOURCE HAD BEEN CONNECTED TO THE BATTERY, CAUSING A MUCH GREATER RATE OF CHARGING. THIS EFFECT ONLY LASTS FOR A FRACTION OF A SECOND, AND IF YOU ARE USING A DC CHARGING SOURCE, IT ONLY OCCURS ONCE DURING THE CHARGING SESSION. HOWEVER, IF WE CHOOSE, WE CAN ARRANGE OUR CHARGING CIRCUIT TO DO THIS SWITCH-ON STYLE OF CHARGING THOUSANDS, OR HUNDREDS OF THOUSANDS OF TIMES EACH SECOND:

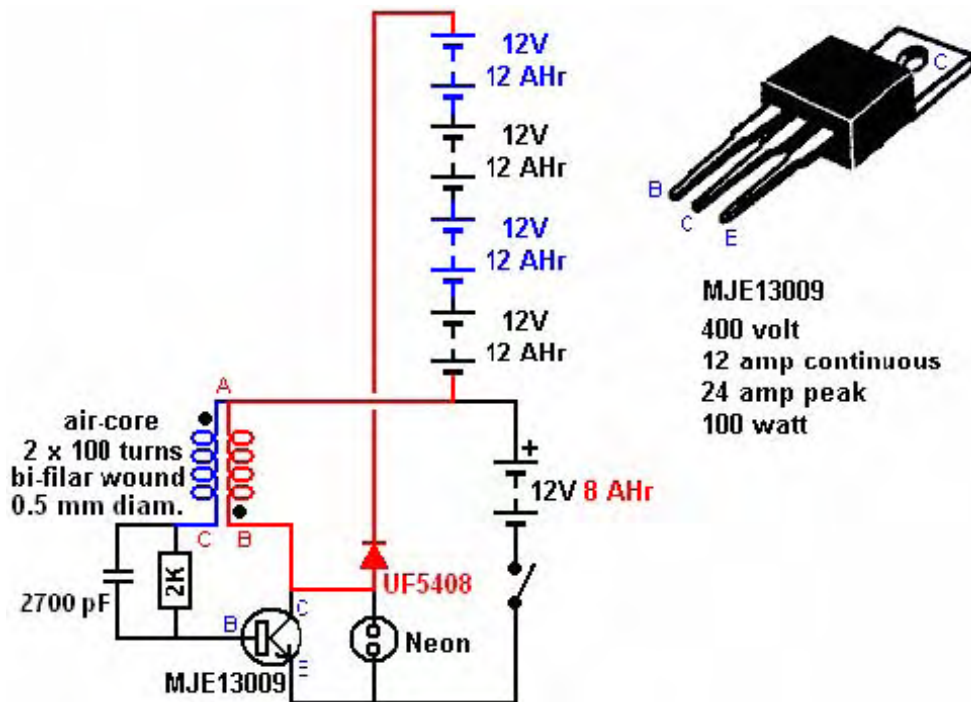

THERE IS A ROOM-TEMPERATURE SUPERCONDUCTOR OF THE UNIVERSAL ENERGY FIELD AND WE CALL IT A "PERMANENT MAGNET". EVERY PERMANENT MAGNET DIRECTS A CONTINUOUS STREAM OF ENERGY THROUGH IT (ALTHOUGH NOT AS SHOWN IN SCHOOLS WHERE THE FIELD IS DISTORTED BY HUNDREDS OF TINY "IRON FILINGS" WHICH THEMSELVES ACT AS TINY MAGNETS DURING THE SCHOOL DEMONSTRATION.

THE PEOPLE WHO HAVE BEEN OPPOSING THE INTRODUCTION OF FREE-ENERGY FOR MORE THAN 100 YEARS NOW TELL US “MAGNETS HAVE POWER BUT THEY CAN’T PERFORM WORK”. THAT STATEMENT IS AS SILLY AS A STATEMENT CAN BE. MAGNETS DO NOT HAVE POWER, INSTEAD, THEY CHANNEL THE UNIVERSAL ENERGY FIELD THROUGH THEM, AND THEY MOST CERTAINLY CAN DO USEFUL WORK.

TAKE THE PERMANENT MAGNET MOTOR OF CHARLES FLYNN AS AN EXAMPLE :

THE VERY IMPRESSIVE PERMANENT MAGNET MOTOR OF CHARLES FLYNN IS SHOWN IN PATENT US 5,455,474 OF OCTOBER 1995. THE PATENT STATES THAT THE MOTOR PRODUCES “A SUBSTANTIAL AMOUNT OF OUTPUT ENERGY AND TORQUE”.

BECAUSE IT HAS A BATTERY YOU MIGHT MISTAKE IT FOR A MOTOR WHICH IS POWERED BY ELECTRICITY, BUT IT IS MOST DEFINITELY NOT. IT IS A MOTOR WHOSE POWER COMES FROM PERMANENT MAGNETS AND THERE IS ELECTROMAGNETIC SCREENING DRIVEN BY A 9-VOLT DRY BATTERY. WITH THAT DRY BATTERY, THE MOTOR REACHES 20,000 RPM. THE BASIC DESIGN IS BASED ON THIS ARRANGEMENT :

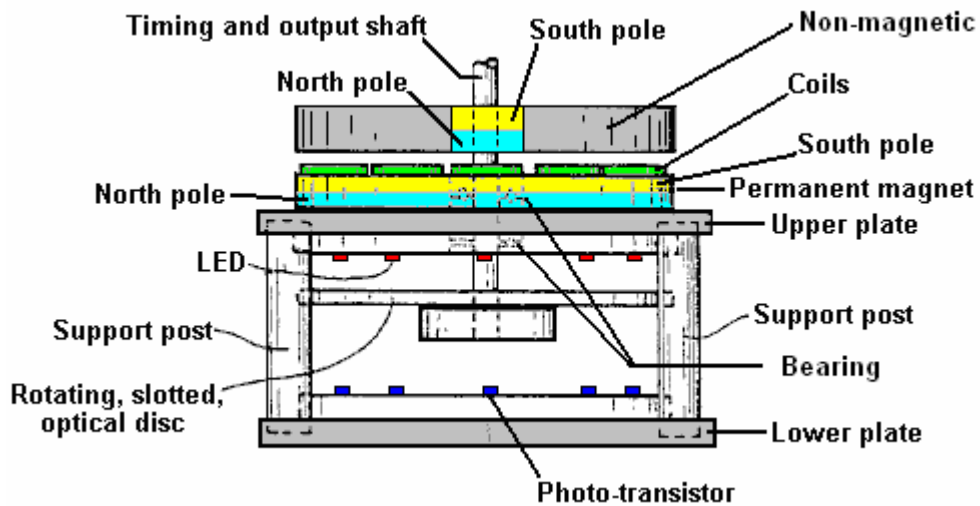

THE VERTICAL OUTPUT DRIVE SHAFT IS MOUNTED ON A BEARING ATTACHED TO THE “UPPER PLATE” AND THEY MAINTAIN THE GAP BETWEEN THE ROTOR AND THE RING MAGNET ATTACHED TO THE UPPER PLATE. THE MAGNET EMBEDDED IN THE NON-MAGNETIC ROTOR CONTINUOUSLY PULLS DOWN TOWARDS THE RING MAGNET.

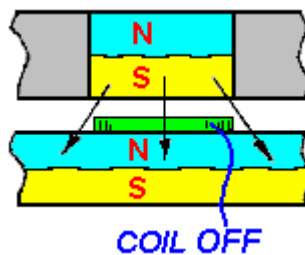

AS DRAWN, THERE IS NOT THE SLIGHTEST INCLINATION FOR THE ROTOR TO ROTATE AS THE ROTOR MAGNET PULLS STRAIGHT DOWN AND EQUALLY TO BOTH SIDES. THE CHALLENGE IS THEREFORE TO PRODUCE A POWERFUL ROTATIONAL MOVEMENT FROM THE ARRANGEMENT. THESE ARE THE WORKING PARTS :

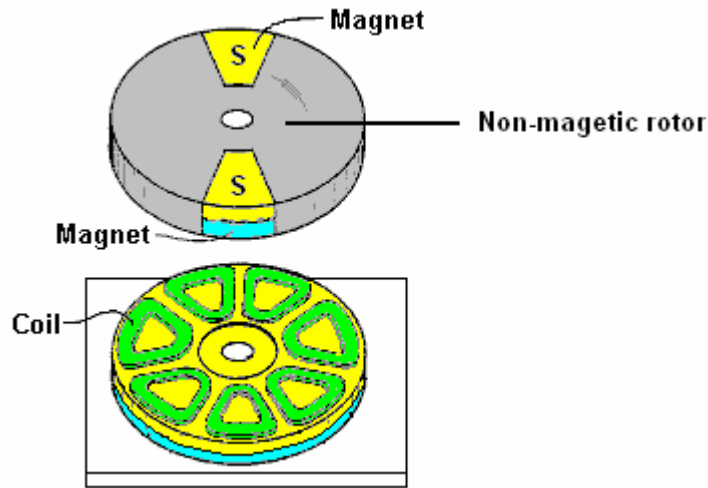

THE KEY FACTOR IS THE SET OF SEVEN COILS AND THE TWO ROTOR MAGNETS. IF ONE ROTOR MAGNET IS DIRECTLY OVER A COIL, THEN THE OTHER MAGNET WILL BE HALF WAY BETWEEN TWO OTHER COILS. THIS IS A CLEVER ARRANGEMENT. WITH NO COIL POWERED UP, THE SITUATION IS THIS :

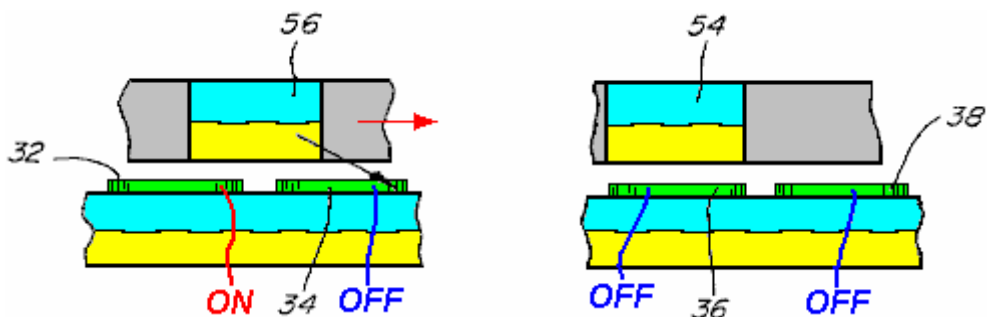

THE SOUTH POLE OF THE ROTOR MAGNET IS ATTRACTED TO THE NORTH POLE OF THE STATOR RING MAGNET. THE ATTRACTION IS MAINLY STRAIGHT DOWN, BUT THERE IS ALSO A PULL TO THE RIGHT AND A PULL TO THE LEFT BUT THESE BALANCE OUT SO THERE IS NO MOVEMENT.

HOWEVER, THE OPPOSITE ROTOR MAGNET STRADDLES TWO COILS :

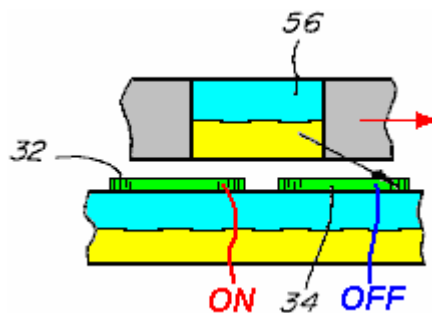

AND IF WE WERE TO TURN ON MAGNET "32" IN SUCH A WAY THAT IT OPPOSES THE ATTRACTION BETWEEN THE ROTOR MAGNET "56" AND THE STATOR RING MAGNET, THEN THERE WILL BE A SIDWAYS PULL TOWARDS COIL "34" AND THE MAGNET WILL MOVE IN THAT DIRECTION AND THEN STOP.

BUT WE DON'T WANT IT TO STOP, SO WE SWITCH ON COIL "34" AT JUST THE RIGHT MOMENT AND THE PROCESS REPEATS. ACTUALLY, THE TWO ROTOR MAGNETS ARE USED ALTERNATELY. THE SWITCHING IS DONE BY A TIMING DISC WHICH IS ATTACHED TO THE ROTOR :



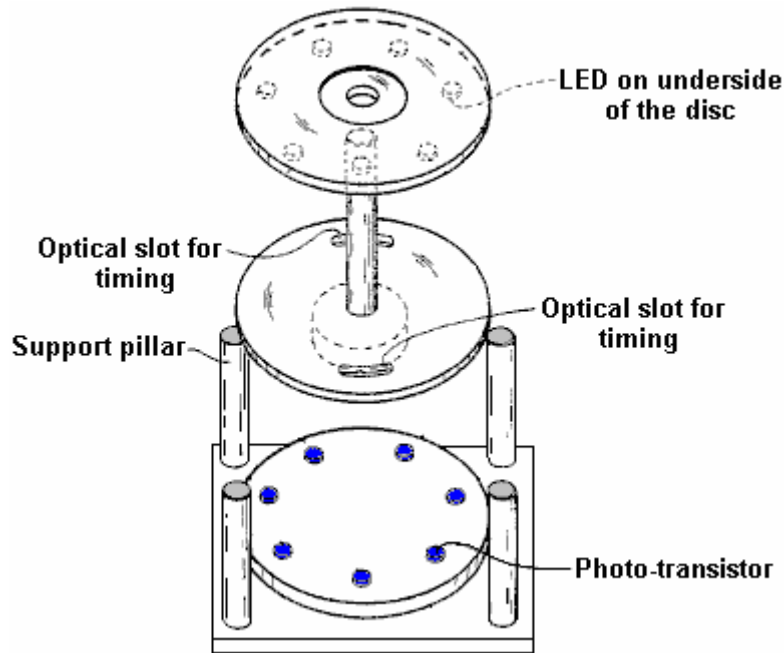

THE TIMING DISC HAS THREE PARTS. ONE HOLDS SEVEN LIGHT-EMITTING DIODES, ANOTHER HAS SEVEN MATCHING PHOTO-TRANSISTORS OR LIGHT-DEPENDENT RESISTORS (THESE ARE POSITIONED EXACTLY UNDER THE SEVEN COILS) AND FINALLY, THE OPTICAL DISC HAS TWO SLOTS CUT IN IT AND THOSE SLOTS ARE POSITIONED EXACTLY UNDERNEATH THE TWO ROTOR MAGNETS.

THE ROTOR IS THE ONLY MOVING PART IN THIS MOTOR. THE OPTICAL DISC IS ATTACHED TO THE ROTOR AND IT SWITCHES ON THE COIL CONNECTED TO THE PHOTO-TRANSISTOR BELOW IT WHEN LIGHT SHINES THROUGH THE SLOT. WITH SEVEN STATOR COILS, THE MOTOR IS SELF-STARTING, AND IN THE STYLE SHOWN SO FAR, ONLY ONE COIL IS POWERED UP AT ANY ONE TIME.

REMEMBER THAT THE TURNING POWER COMES FROM THE UNIVERSAL ENERGY FIELD FLOWING THROUGH THESE PERMANENT MAGNETS.

THE NEXT STEP IN THE DEVELOPMENT OF THE MOTOR IS TO ADD ANOTHER STATOR RING MAGNET AND COILS, ABOVE THE ROTOR, LIKE THIS :

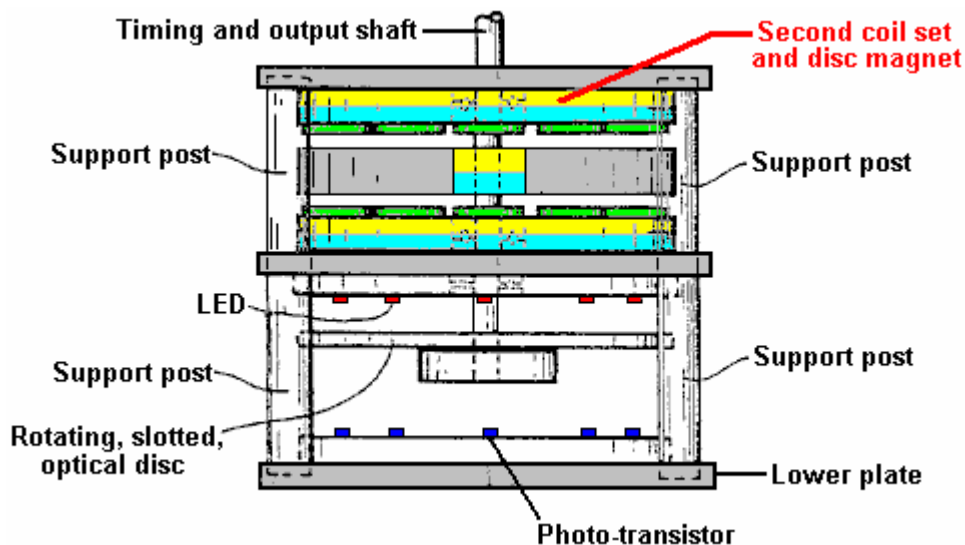

THE SWITCHING FOR THE EXTRA COILS IS IDENTICAL TO THAT OF THE LOWER SET OF COILS AND THE ROTOR RECEIVES A MUCH BETTER BALANCED AND LARGER THRUST :

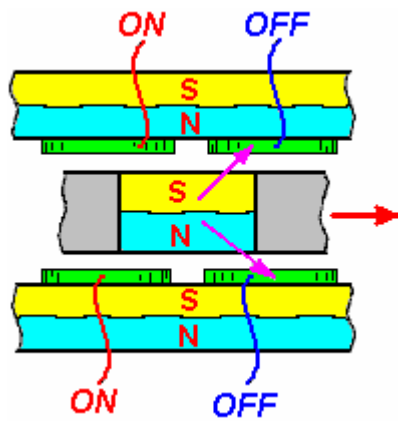

WITH THIS ARRANGEMENT, TWO COILS ARE POWERED UP AT ANY ONE MOMENT. BUT, OF COURSE, THIS SET-UP CAN BE REPLICATED AS MANY TIMES AS YOU WISH WITH THE MOTOR POWER INCREASING TO A MAJOR DEGREE WITH EVERY ADDED DRIVE SECTION. HERE IS AN ARRANGEMENT WITH FOUR DRIVE SECTIONS :

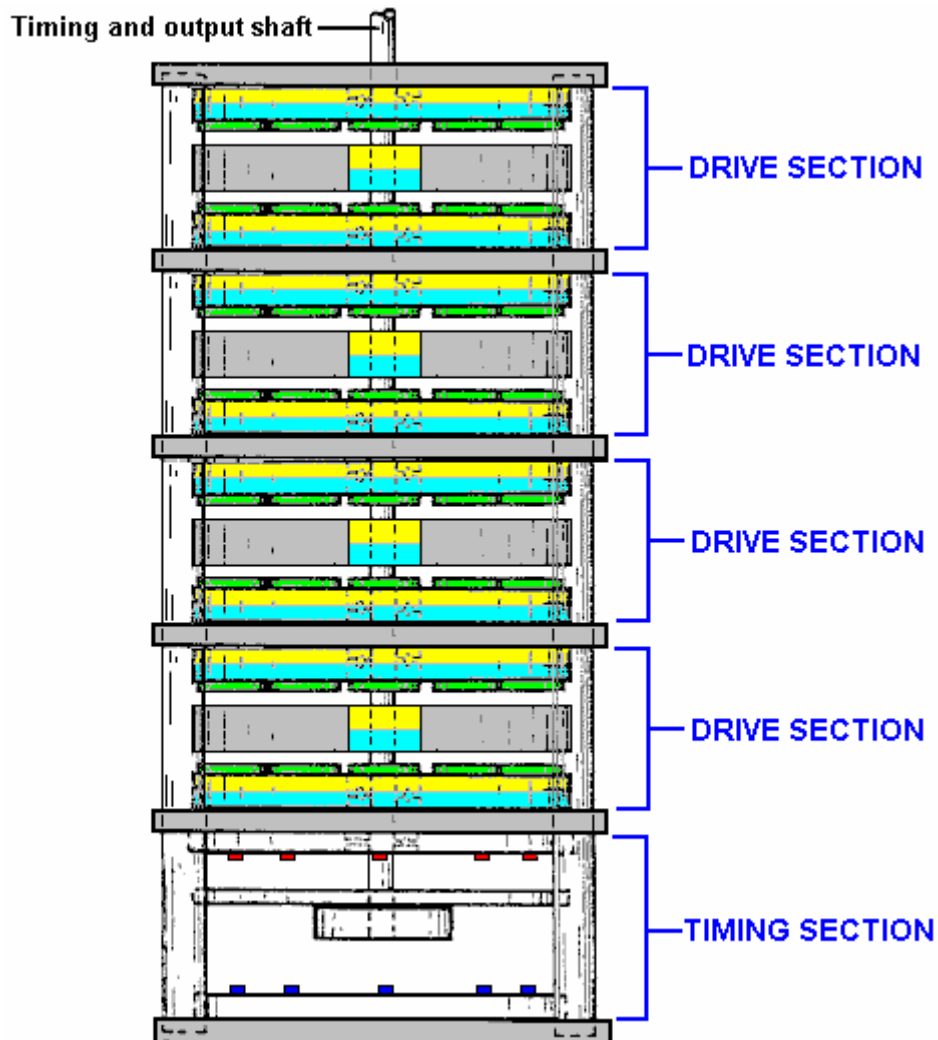

HERE IS CHARLES FLYNN'S' CIRCUIT FOR DRIVING ONE OF THE COILS :

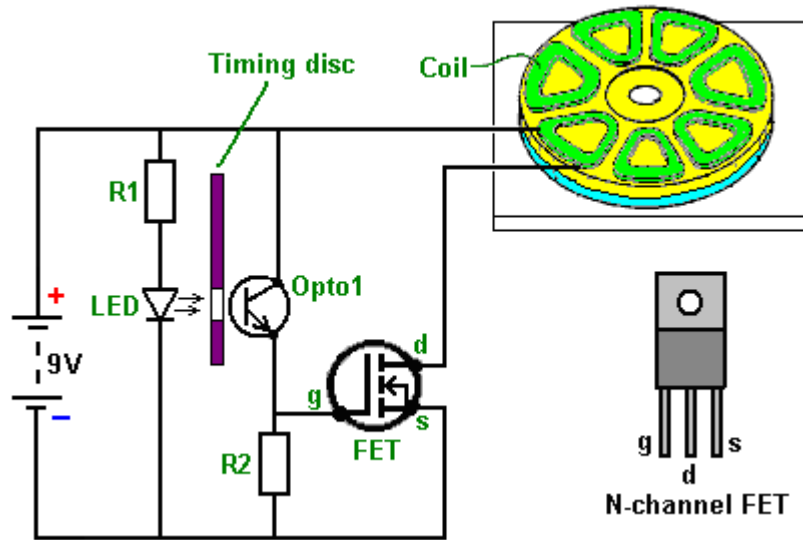

THERE ARE SEVEN OF THESE CIRCUITS, ONE FOR EACH COIL, WITH JUST TWO SHOWN HERE :

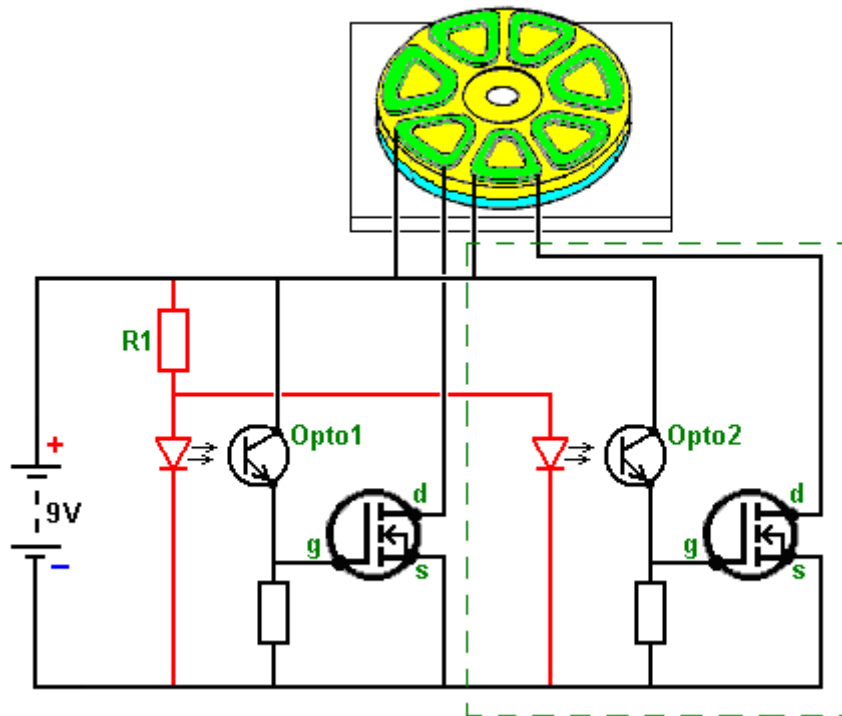

IF, AS WOULD BE NORMAL, SEVERAL SETS OF MAGNETS ARE BEING USED, THEN THE COILS POSITIONED DIRECTLY ABOVE EACH OTHER CAN BE CONNECTED IN A CHAIN LIKE THIS :

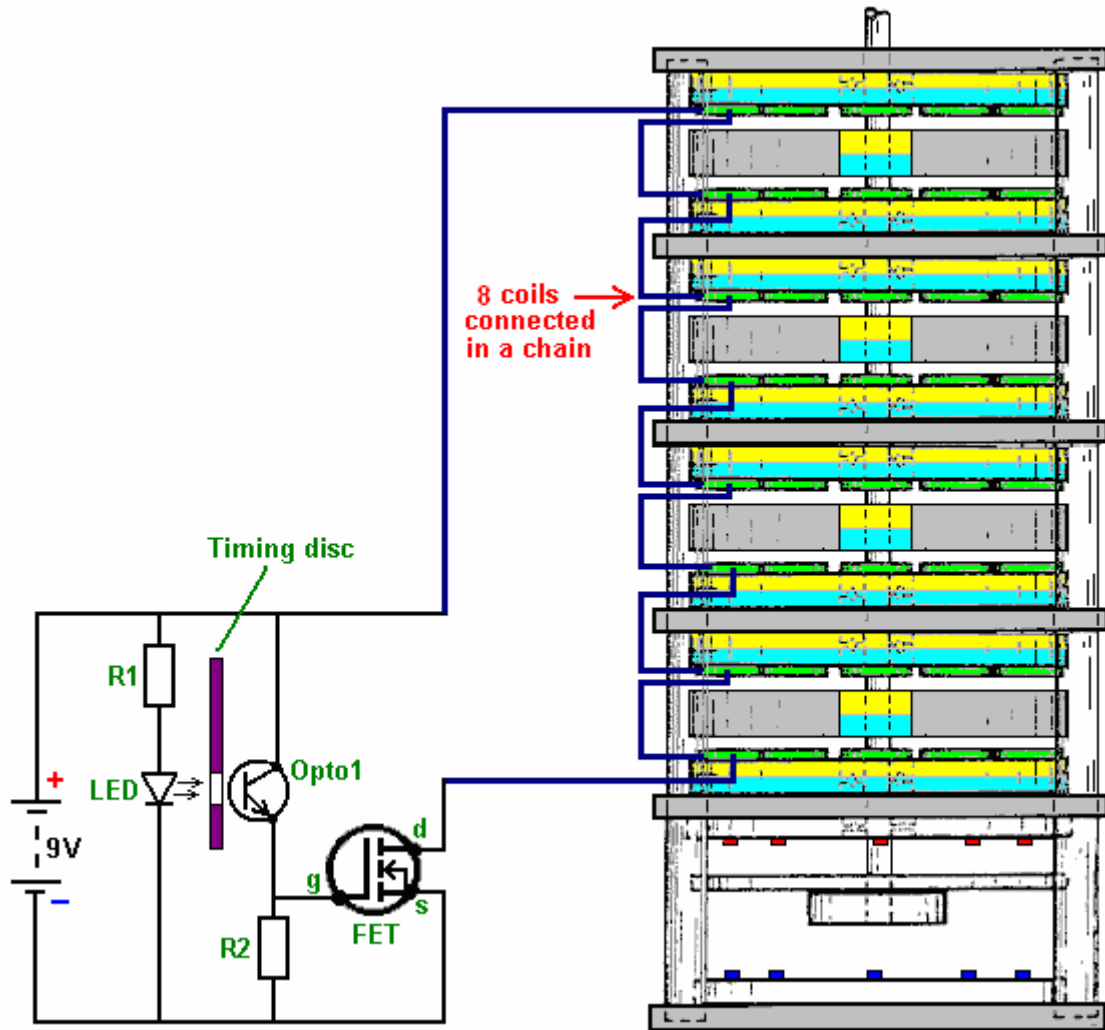

AS THERE ARE SEVEN COILS ON EACH STATOR MAGNET, THERE WILL BE SEVEN OF THESE VERTICAL CHAINS, DRIVEN BY SEVEN TRANSISTORS AS SHOWN ABOVE.

THIS IS A VERY SIMPLE AND STRAIGHTFORWARD MAGNET MOTOR WITH ALL OF THE OUTPUT POWER COMING FROM THE MAGNETS AND NONE FROM THE BATTERY WHICH IS ONLY USED AS AN ELECTROMAGNETIC SHIELD TO PRODUCE UNBALANCED FORCES.

I KEEP GETTING ASKED "WHAT DIAMETER WIRE AND HOW MANY TURNS FOR EACH COIL?" BUT THERE IS NO ANSWER TO THAT. THE MAGNETIC EFFECT OF A COIL IS NOT RELATED TO THE POWER FED INTO IT AND A COIL WITH MANY TURNS OF FINE WIRE, DRAWING LITTLE CURRENT CAN EASILY HAVE A STRONGER MAGNETIC FIELD THAN A COIL WITH FEWER TURNS OF THICKER WIRE AND MUCH HIGHER CURRENT DRAW, ALTHOUGH THOSE TWO COILS WOULD HAVE DIFFERENT RESPONSE TIMES, BACK-EMF PULSES, ETC.

ALSO, MAGNETS VARY A GREAT DEAL IN THEIR STRENGTH AND THERE IS NO WAY THAT I CAN KNOW HOW POWERFUL YOUR MAGNETS ARE. FINALLY, THE GAP BETWEEN THE ROTOR MAGNETS AND STATOR MAGNETS MAKES A MAJOR DIFFERENCE.

SO, I SUGGEST THAT YOU CONSTRUCT THE BASIC FIRST STEP OF THIS :

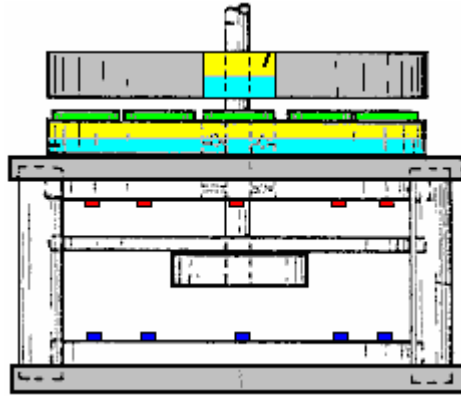

WHERE THERE IS JUST ONE STATOR RING MAGNET, CHOOSE THE GAP BETWEEN THE ROTOR AND THE STATOR. THEN, CHOOSE A WIRE DIAMETER AND WIND A COIL TO SEE WHAT EFFECT IT HAS. TRY DIFFERENT COILS TO SEE WHAT WORKS REALLY WELL WITH YOUR MAGNETS AND THEN USE THAT COIL EVERYWHERE.

WHILE THE ROTOR MAGNETS ARE SHOWN AS TAPERED TOWARDS THE OUTPUT SHAFT, THAT IS NOT ESSENTIAL AND RECTANGULAR MAGNETS CAN BE USED.

LET US MOVE ON TO THE PERMANENT MAGNET MOTOR OF ROBERT ADAMS. WHEN HE WAS 70 YEARS OLD, ROBERT ADAMS OF NEW ZEALAND DESIGNED A VERY EFFECTIVE MOTOR/GENERATOR. HE WAS TOLD TO DESTROY HIS DEVICE OR HE WOULD BE KILLED. ROBERT DECIDED THAT AT HIS AGE, HE HAD VERY LITTLE TO LOSE AND SO HE PUBLISHED HIS DESIGN.

HIS MOTOR OVERCOMES THE LENZ'S LAW DRAG EFFECT AND THROUGH CLEVER ENGINEERING, ACHIEVES A POWER OUTPUT WHICH IS EIGHT TIMES GREATER THAN THE INPUT POWER. AND ALTHOUGH IT DOES NOT LOOK AS IF IT IS, HIS DESIGN IS ACTUALLY A PERMANENT MAGNET MOTOR.



THE DIAGRAM OF HIS MOTOR WHICH IS SUPPOSED TO SHOW HOW IT WORKS IS THIS :

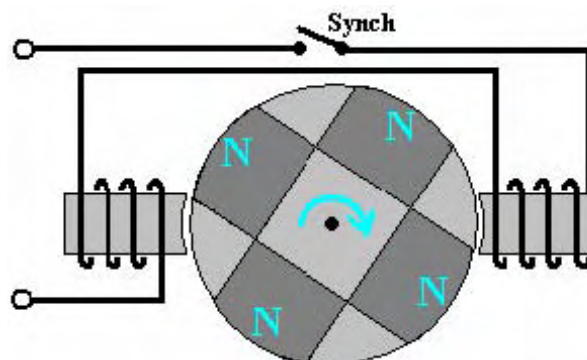

THIS GIVES THE IMPRESSION THAT THE ROTATION OF THE ROTOR CARRYING THE PERMANENT MAGNETS IS DRIVEN BY ELECTRICAL PULSES LIKE JOHN BEDINI'S FAMOUS MOTOR. IT ISN'T. THIS IS A PERMANENT MAGNET MOTOR AND THE ROTATION OF THE ROTOR IS CAUSED PRIMARILY BY THE MAGNETS IN THE ROTOR BEING ATTRACTED TO THE SOLID IRON CORES OF THE TWO "DRIVE" ELECTROMAGNETS SHOWN IN THE DIAGRAM ABOVE.

THE ELECTROMAGNETS CONFUSE PEOPLE AS THEY DON'T REALISE THAT THE LEVEL OF POWER APPLIED TO THEM IS SO LOW THAT IT ONLY JUST CANCELS THE BACKWARD DRAG OF THE MAGNETS AS SOON AS THEY PASS THE ELECTROMAGNET CORES. THAT HAPPENS FOUR TIMES PER ROTATION AND THE POWER IS ONLY SWITCHED ON WHEN THE ROTOR MAGNET IS EXACTLY ALIGNED WITH THE ELECTROMAGNET, AND THEN ONLY BRIEFLY.

THESE TWO ELECTROMAGNETS ALONG WITH THEIR VERY CAREFULLY TIMED ELECTRIC PULSES ARE THE ENTIRE DRIVE FOR THE GENERATOR. THE TIMING OF THE "DRIVE" COIL PULSES IS ARRANGED BY AN OPTICAL TIMING DISC OF THIS TYPE :

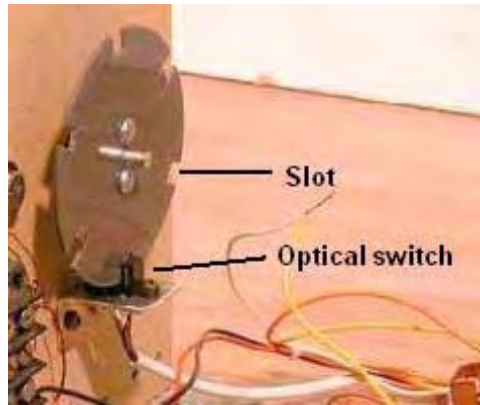

SENSOR :

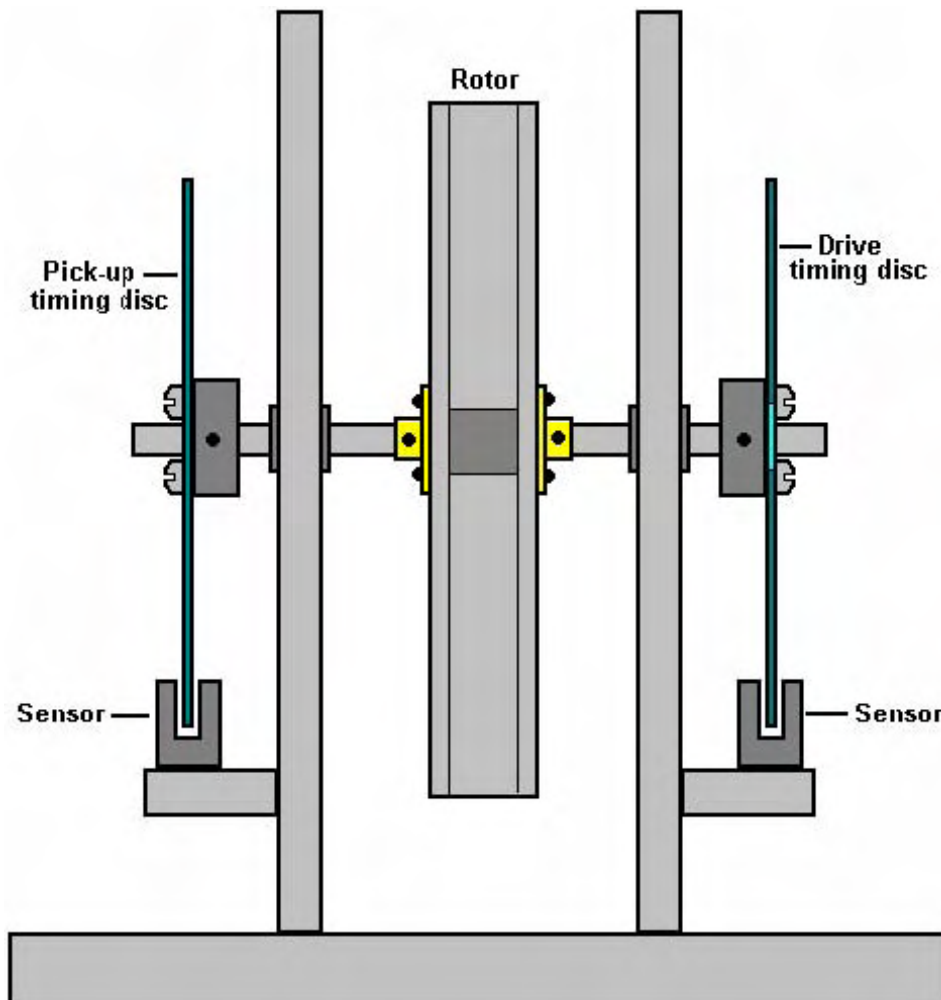

LET'S CONCENTRATE ON THE DRIVE FOR THE MOMENT. AFTER MUCH EXPERIMENTATION, ROBERT FOUND THAT THE MOST EFFICIENT ARRANGEMENT IS WHEN THE CORES OF THE "DRIVE" ELECTROMAGNETS HAVE HALF THE CROSS-SECTIONAL AREA OF THE CROSS-SECTIONAL AREA OF THE ROTOR MAGNETS. SO, IF THE ROTOR MAGNETS HAVE A CIRCULAR CROSS-SECTION, THEN THEIR DIAMETER WOULD BE TWICE THAT OF CIRCULAR DRIVE ELECTROMAGNETS.

ROBERT ALSO FOUND THAT THE BEST GAP BETWEEN THE ROTOR MAGNETS AND THE DRIVE ELECTROMAGNETS IS ABOUT HALF AN INCH WHICH IS 12mm.

A FURTHER TWEAK TO THE DRIVE SYSTEM IS THE FACT THAT THE DRIVE ELECTROMAGNETS ARE FED A CONTINUOUS STREAM OF ELECTRIC PULSES. WHEN A COIL IS POWERED UP AND THEN THE CURRENT SWITCHED OFF, THE COIL GENERATES A REVERSE VOLTAGE PULSE SOMETIMES CALLED THE "BACK-EMF" PULSE. IN ROBERT'S MOTOR/GENERATOR THOSE BACK-EMF PULSES ARE USED TWICE.

FIRST, AS THE COILS WERE ENERGISED IN ORDER TO OPPOSE THE ATTRACTION BETWEEN THE ROTOR MAGNETS AND THE ELECTROMAGNET CORES, THE BACK-EMF BEING IN THE OPPOSITE DIRECTION, CAUSES THE REVERSE EFFECT, INCREASING THE ATTRACTION TO THE NEXT APPROACHING ROTOR MAGNET.

SECOND, ROBERT RECTIFIES THE BACK-EMF PULSES AND FEEDS THEM BACK TO THE DRIVE BATTERY AND THAT RECOVERS 95% OF THE CURRENT NEEDED TO MAKE THE GENERATOR WORK.

NOW WE COME TO THE POWER GENERATING SYSTEM AND ONE PERSON WHO REPLICATED THIS DEVICE HAS AN EXCESS OUTPUT OF 33 KILOWATTS AND THAT POWERS HIS HOUSE AND HIS BUSINESS.

THE POWER GENERATION IS THROUGH FOUR ADDITIONAL ELECTROMAGNETS WHICH ACT AS PICK-UP COILS. THIS IS ROBERT'S DRAWING OF HIS ARRANGEMENT :

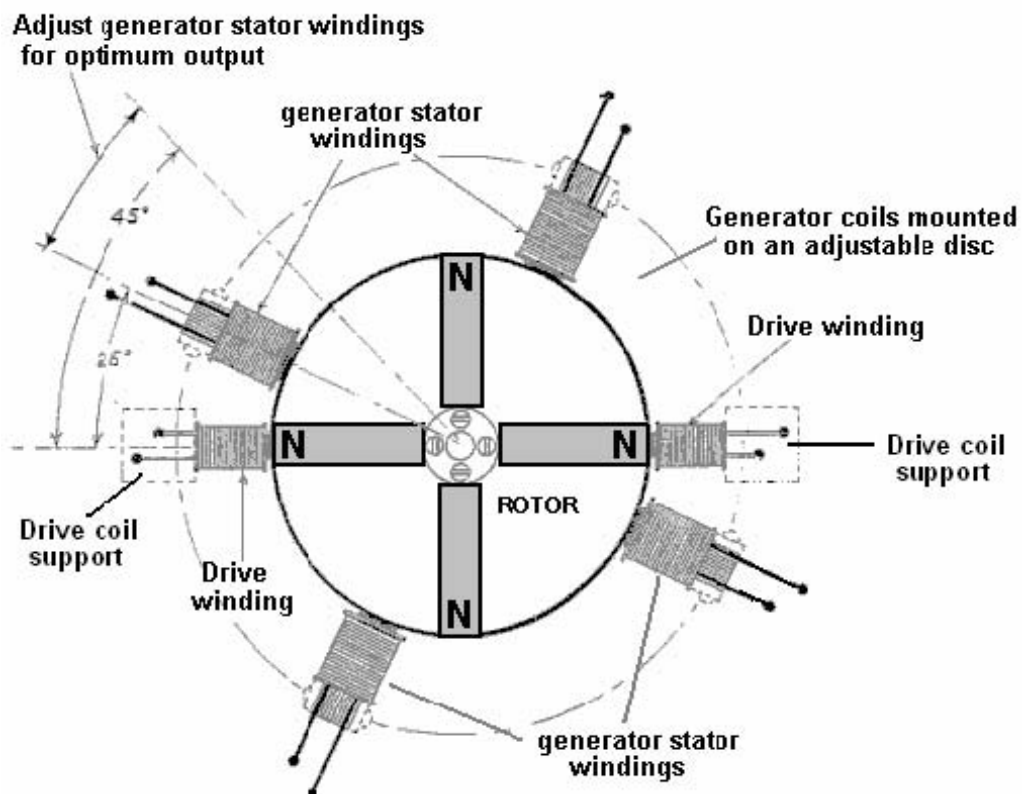

NOTICE A NUMBER OF THINGS HERE : THE FOUR GENERATOR COILS ARE PHYSICALLY ATTACHED TO A DISC OR RING WHILE THE TWO DRIVE COILS ARE MOUNTED SEPARATELY. THIS MEANS THAT

THE GAP BETWEEN THE GENERATOR COILS AND THE DRIVE ELECTROMAGNETS CAN BE ADJUSTED WHILE THE MOTOR IS RUNNING.

ALSO, THE WIDTH OF THE CORES OF THE GENERATOR COILS IS VERY MUCH GREATER THAN THE WIDTH OF THE CORES OF THE DRIVE COILS, AND THE GENERATOR COILS ARE NEARLY SQUARE IN THIS DRAWING.

NEXT, NOTICE THE PROPORTIONS OF THE ROTOR MAGNETS – THEY ARE VERY MUCH LONGER THAN THEY ARE WIDE, SEPARATING THE OUTER NORTH POLES FROM THE INNER SOUTH POLES. HOWEVER, A POINT WHICH SEEMS TO ESCAPE MOST PEOPLE IS THE FACT THAT A CRITICAL PART OF THE DESIGN IS THE TECHNIQUE OF CUTTING OFF THE OUTPUT POWER AT THE APPROPRIATE MOMENT. CUTTING OFF THE OUTPUT POWER SOUNDS ALL WRONG TO MOST PEOPLE AND YET IT IS A VERY IMPORTANT THING TO DO.

THE REASON IS THE SAME AS FOR THE DRIVE COILS. IF YOU DON'T CUT OFF THE ELECTRICAL CONNECTION, THEN THE ATTRACTION BETWEEN THE SOLID IRON CORES OF THE GENERATOR COILS AND THE ROTOR MAGNETS TRIES TO PULL THE ROTOR MAGNETS BACK TOWARDS THE FIXED GENERATOR COIL CORES – AN EFFECT CALLED “DRAG”. BUT, IF THE OUTPUT CURRENT GENERATED IN THE COILS BY THE PASSING MAGNETS IS CUT OFF AT JUST THE RIGHT INSTANT, THEN THE BACK-EMF GENERATED BY THAT CUT-OFF CAUSES A MAGNETIC FIELD IN THE GENERATOR COILS WHICH BOOSTS THE ROTOR ON ITS WAY INSTEAD OF DRAGGING IT BACKWARDS.

ROBERT ALSO RECTIFIES THAT BACK-EMF PULSE AND FEEDS IT BACK TO THE DRIVE BATTERY. SO FAR, THIS IS A HIGHLY EFFICIENT SYSTEM.

ROBERT'S DIAGRAM DOES NOT SHOW WHEN THE GENERATOR COILS ARE BEST SWITCHED ON OR OFF. A BUILDER WITH A FORUM ID OF “MAMARIATI” FOUND OPTIMUM SWITCHING WITH THE OUTPUT POWER SWITCH ON AT 42 DEGREES AND SWITCH OFF AT 44.7 DEGREES. THAT TINY 2.7 DEGREE PART OF THE ROTOR TURN GAVE HIM AN INPUT OF 27.6 WATTS AND AN OUTPUT OF 33.78 KILOWATTS WHICH IS A COP=1223 OR 122,300% WHICH IS SPECTACULAR.

IT IS SUGGESTED THAT A GOOD LENGTH FOR THE GENERATOR COILS IS SHOWN WHEN YOUR PARTICULAR ROTOR MAGNETS JUST START TO LIFT ONE END OF A 32mm PAPER CLIP OFF THE TABLE LIKE THIS :

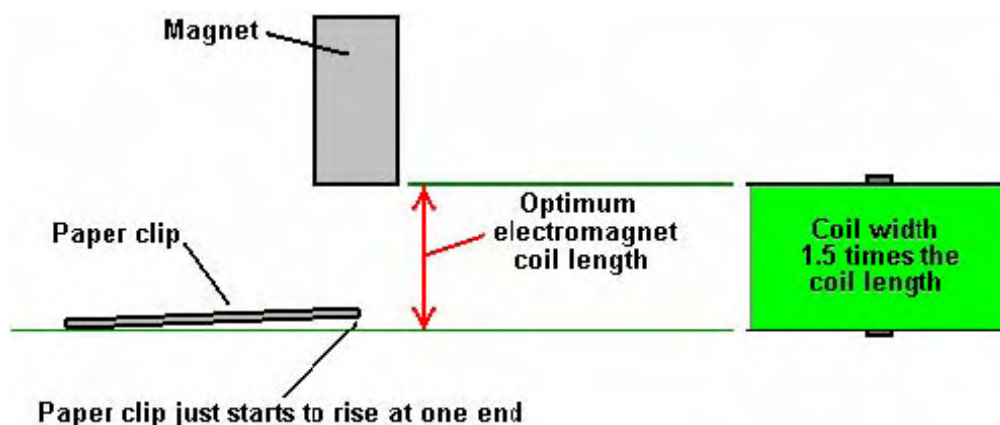

ROBERT TAKES HIS DESIGN FURTHER BY USING SHORT PULSES OF CURRENT.

THIS IS SOMETHING WHICH IS DONE AFTER THE ROTOR OPERATION HAS BEEN OPTIMISED USING CONTINUOUS BATTERY POWER, THAT IS, AFTER MOVING THE GENERATOR COILS ON THEIR DISC TO FIND THE VERY BEST PERFORMANCE POSITION. ROBERT PREFERRED TO USE MECHANICAL CONTACTS ON A ROTATING DISC AS SHOWN HERE :



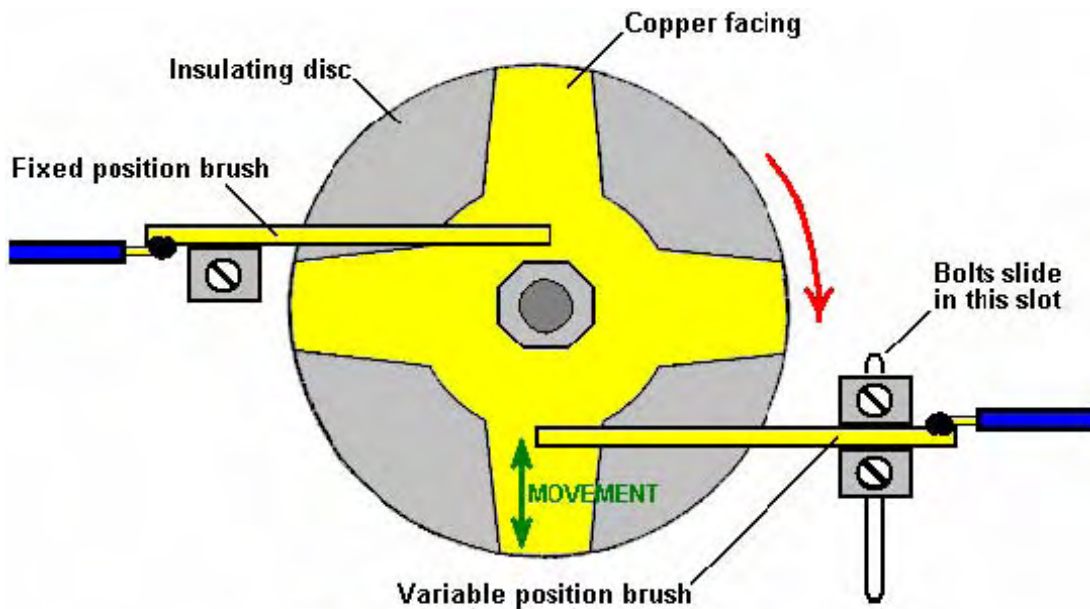

**TIMING GEAR - TOP VIEW**

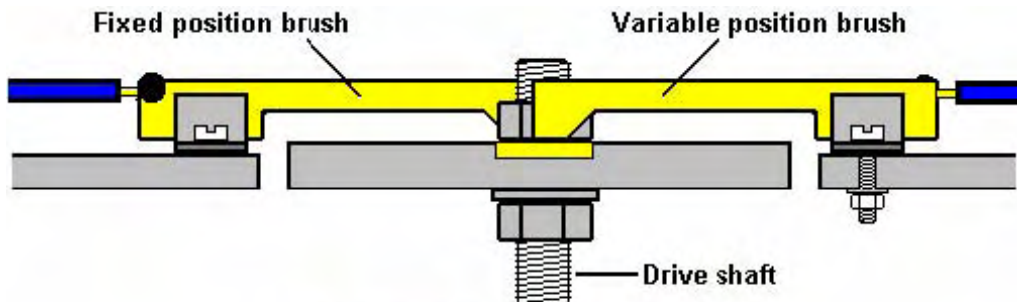

**TIMING GEAR - SIDE VIEW**

THE OBJECTIVE IS TO ADJUST THE VARIABLE POSITION BRUSH CONTACT TO GET THE INPUT POWER CONNECTED TO THE MOTOR/GENERATOR FOR ONLY ABOUT 25% OF THE TIME. THE TIMING DISC SHOWN ABOVE IS ATTACHED TO THE ROTOR SHAFT AND SO NO ADDITIONAL POWER IS NEEDED TO ACHIEVE THE SWITCHING, AND THE SWITCHING ALLOWS CURRENT FLOW IN BOTH DIRECTIONS WHICH IS CONVENIENT.

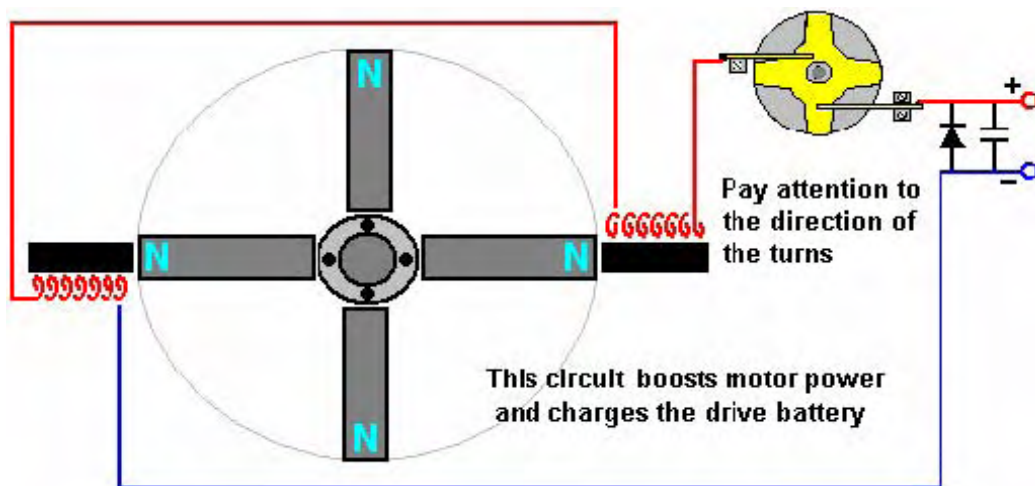

THE DIODE AND CAPACITOR RETURN THE BACK-EMF PULSES TO THE DRIVING BATTERY.

THE OVERALL MOTOR/GENERATOR CIRCUIT IS LIKE THIS :

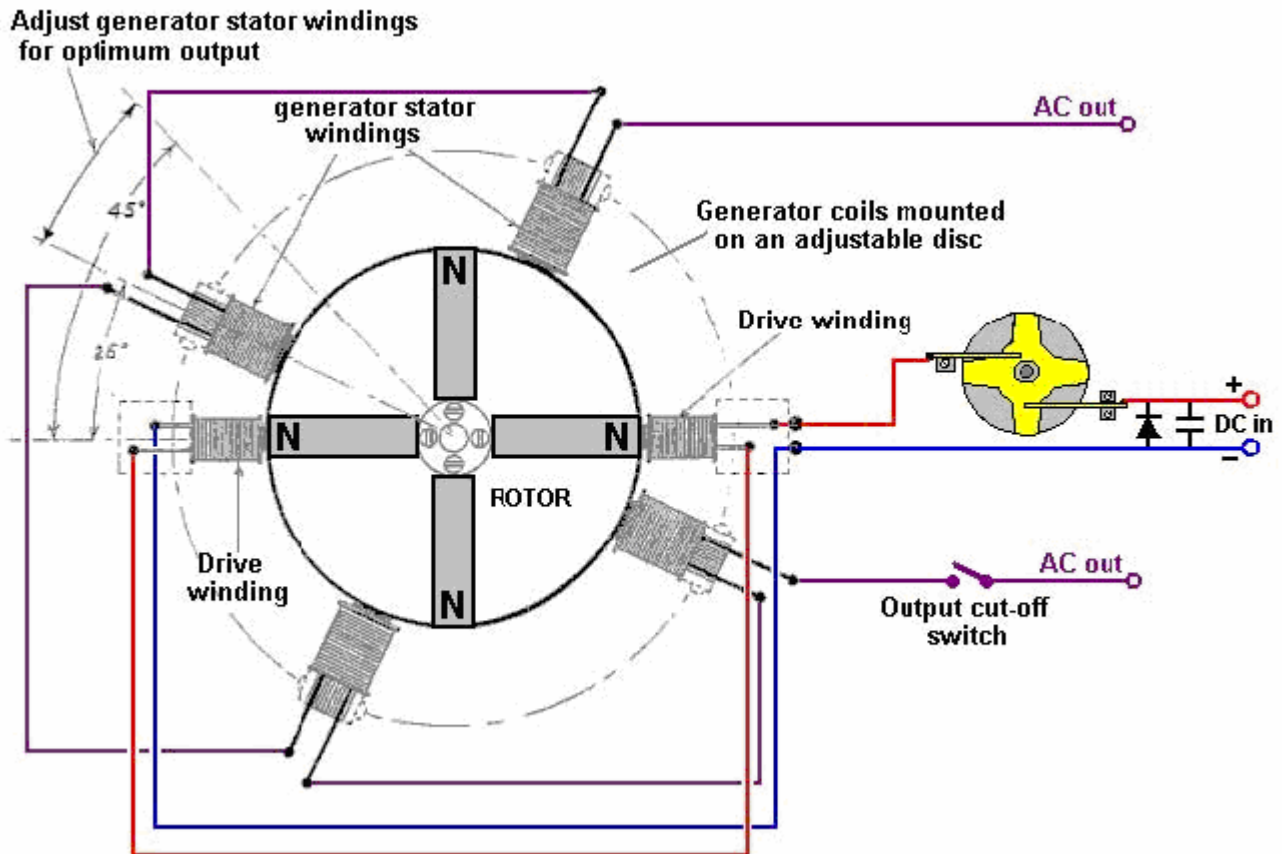

ROBERT ADAMS ADVISES THE FOLLOWING :

1. USE ONLY PURE IRON FOR THE CORES OF THE DRIVE AND GENERATOR COILS.
2. WIND THE GENERATOR COILS WITH A RESISTANCE IN THE RANGE OF 10 TO 20 OHMS FOR A SMALL MODEL.
3. USE A VOLTAGE BETWEEN 12 VOLTS AND 36 VOLTS FOR A SMALL MODEL.
4. FOR A SMALL MACHINE, MAKE THE CONTACTOR STAR DISC 1 INCH MAXIMUM DIAMETER.
5. KEEP WIRING SHORT AND OF A LOW RESISTANCE.
6. FOR A SMALL MACHINE, USE A FUSE OF 500 MILLIAMPS TO 1 AMP.
7. INSTALL A SWITCH FOR CONVENIENCE AND SAFETY.
8. USE SMALL BEARINGS. DO NOT USE SEALED BEARINGS DUE TO THEIR GREASE DRAG.
9. USE ONLY SILVER CONTACTS FOR THE PULSE SWITCHING.
10. IF USING POWERFUL MAGNETS, VIBRATION BECOMES A PROBLEM.
11. THE AIR GAP IS NOT CRITICAL, BUT REDUCING IT INCREASES BOTH TORQUE AND INPUT POWER IN PROPORTION.
12. FOR HIGHER VOLTAGE AND LOWER CURRENT, CONNECT THE GENERATOR COILS IN SERIES.
13. IF THE DRIVE COIL WINDINGS ARE LOW RESISTANCE AND THE INPUT VOLTAGE IS HIGH, THEN IT IS ADVISABLE TO USE A TRANSISTOR TO ELIMINATE SPARKING.
14. TUNING THE POINTS IS VITALLY IMPORTANT UNLESS USING TRANSISTOR SWITCHING.
15. USE FERRITE MAGNETS FOR ALL INPUT VOLTAGES BELOW 120 VOLTS.
16. IF CONSTRUCTING A LARGE MODEL INVOLVING LARGE SUPER-POWER MAGNETS, THEN GREATER POWER IS NEEDED TO DRIVE THE MACHINE, THE GREATER THE TORQUE, THE GREATER THE VIBRATION, THE GREATER THE COPPER CONTENT, ETC.

PLEASE REMEMBER THAT ANY WIRING THAT YOU USE NEEDS TO BE ABLE TO CARRY THE

**CURRENT WITHOUT OVERHEATING. HERE ARE SOME CABLE CAPACITIES :**

AWG	Dia mm	Area sq. mm	SWG	Dia mm	Area sq. mm	Max Amps	Ohms / metre	Metres Per 500g
1	7.35	42.40	2	7.01	38.60	119		
2	6.54	33.60	3	6.40	32.18	94		
3	5.88	27.15	4	5.89	27.27	75		
4	5.19	21.20	6	4.88	18.68	60		
5	4.62	16.80	7	4.47	15.70	47		
6	4.11	13.30	8	4.06	12.97	37		
7	3.67	10.60	9	3.66	10.51	30		
8	3.26	8.35	10	3.25	8.30	24		
9	2.91	6.62	11	2.95	6.82	19		
10	2.59	5.27	12	2.64	5.48	15	0.0042	
11	2.30	4.15	13	2.34	4.29	12	0.0047	
12	2.05	3.31	14	2.03	3.49	9.3	0.0053	17.5 m
13	1.83	2.63	15	1.83	2.63	7.4	0.0068	
14	1.63	2.08	16	1.63	2.08	5.9	0.0083	27 m
15	1.45	1.65	17	1.42	1.59	4.7	0.0135	
16	1.29	1.31	18	1.219	1.17	3.7	0.0148	48 m
17	1.15	1.04				2.9	0.0214	
18	1.024	0.823	19	1.016	0.811	2.3	0.027	
19	0.912	0.653	20	0.914	0.657	1.8	0.026	85 m
20	0.812	0.519	21	0.813	0.519	1.5	0.036	

**TO SUMMARISE THEN, A PROPERLY BUILT ADAMS MOTOR IS A SMALL, DESK-TOP DEVICE WHICH PULLS IN A GREAT DEAL OF EXCESS ENERGY FROM THE UNIVERSAL ENERGY FIELD, ENERGY WHICH CAN POWER A HOUSEHOLD, PROVIDE HEATING, COOLING, SMOKE-FREE COOKING, LIGHTING, CLEAN WATER AND POWER FOR COMPUTERS, MOBILE PHONES, E-READERS, MP3 PLAYERS ETC.**

**IT IS IMPORTANT TO UNDERSTAND THE REALITY OF THE UNIVERSE. THERE IS NO SUCH THING AS GRAVITY. WHAT WE CALL "THE FORCE OF GRAVITY" DOES NOT PULL – IT PUSHES AND IT IS IN REALITY JUST A SLIGHT IMBALANCE IN THE ZERO-POINT ENERGY FIELD WHICH ACTS IN ALL DIRECTIONS. THE IMBALANCE IS CAUSED BY A LARGE VOLUME OF MATTER ABSORBING SOME OF THE ZERO-POINT ENERGY FIELD WHICH PASSES THROUGH IT – THE LARGER THE MASS OF MATTER, THE GREATER THE IMBALANCE OR "GRAVITY".**

**THE "THESTICA" MACHINE DESIGNED BY PAUL BAUMANN OF SWITZERLAND IS A SELF-POWERED 3 KILOWATT OUTPUT GENERATOR WHICH USES THE ELECTROSTATIC OUTPUT OF A WIMSHURST MACHINE AS ITS INPUT.**

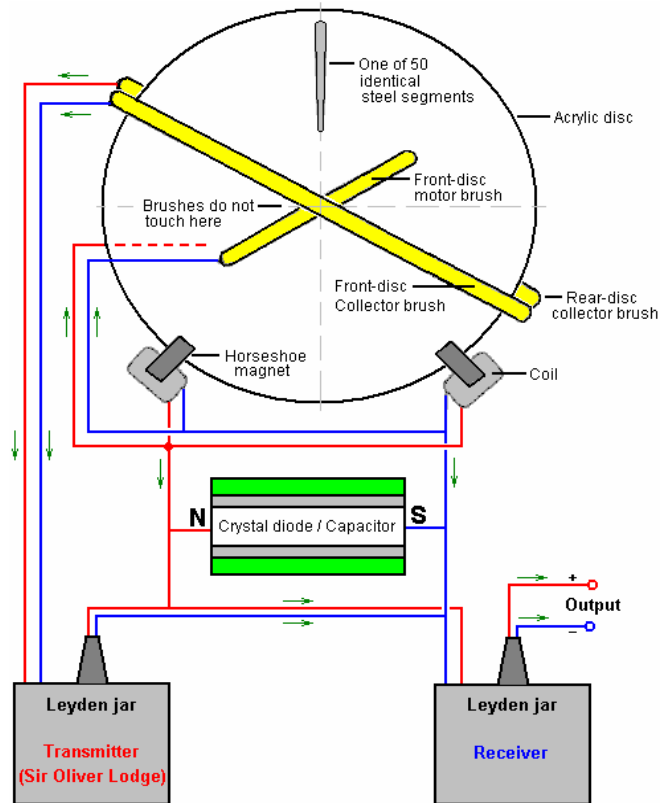

THE IMPORTANT POINT TO NOTE IS THAT THE WIMSHURST MACHINE USED BY PAUL BAUMANN IS SELF ROTATING DUE TO THE MOTOR STRIPS ANGLED AT 45 DEGREES. THE ROTATION IS APPROXIMATELY 60 RPM OR ONCE PER SECOND. IN 1991, DON KELLY STATED THE "SWISS M-L CONVERTER" IS A FULLY SYMMETRICAL, INFLUENCE-TYPE ENERGY CONVERTER WHICH IS BASED ON THE WIMSHURST ELECTROSTATIC GENERATOR WITH ITS TWIN COUNTER-ROTATING DISCS WHERE METALLIC FOIL SECTORS GENERATE AND CARRY SMALL CHARGES OF ELECTRICITY TO BE STORED IN MATCHING CAPACITORS. IN WIMSHURST UNITS, DIAGONAL NEUTRALISING BRUSHES ON EACH OPPOSITE DISC DISTRIBUTE THE CORRECT CHARGES TO THE SECTORS AS THEY REVOLVE, BUT IN THE M-L CONVERTER THIS IS CARRIED OUT BY A CRYSTAL DIODE WHICH HAS A HIGHER EFFICIENCY. THE TWO DISCS ARE MADE OF ACRYLIC AND THE METALLIC SEGMENTS ARE STEEL AND THE ELECTROMAGNETIC CONVERSION IS MADE AT THE RIM THROUGH PASSIVE ELECTROMAGNETS.



THE SELF-PROPULSION AFTER HAND STARTING THE DISCS IS ACHIEVED THROUGH THE JOE POGGENDORFF PRINCIPLE IN WHICH SLANTED CONDUCTIVE BRUSHES COLLECT A HIGH CHARGE AND THAT CHARGE PRODUCES SELF-ROTATION IN ELECTROSTATIC MOTORS (BUT NOT GENERATORS). SO, PAUL BAUMANN'S ELECTROSTATIC WHEEL PRODUCES A CONTINUOUS SOURCE OF ELECTROSTATIC ENERGY WITHOUT NEEDING ANY FORM OF INPUT POWER.

IT IS IMPORTANT TO UNDERSTAND THAT THE SUN DOES NOT PRODUCE ENERGY BY NUCLEAR FUSION OF HYDROGEN INTO HELIUM. THE REALITY IS THAT THE ENERGY COMING FROM THE SUN IS CAUSED BY THE ZERO-POINT ENERGY FIELD WHICH IS THE UNIVERSAL ENERGY FIELD, AND SO

USING AN AERIAL TO ACCESS THAT ENERGY IS JUST ANOTHER METHOD OF ACCESSING THE UNIVERSAL ENERGY FIELD. A GREAT DEAL OF WHAT YOU WERE TAUGHT IN SCHOOL IS EITHER WRONG OR ONLY PARTIALLY RIGHT. FOR EXAMPLE, IT IS CLAIMED THAT ACCORDING TO ARCHIMEDIES, A BODY WILL FLOAT ONLY IF IT DISPLACES IT'S OWN WEIGHT OF LIQUID. MY SCIENCE TEACHER IN SCHOOL DEMONSTRATED THAT THAT IS NOT CORRECT BY FLOATING A BRASS CYLINDER IN MERCURY WHERE THE WEIGHT OF MERCURY WAS LESS THAN THE WEIGHT OF THE BRASS CYLINDER. FOR THAT, HE USED A GLASS CONTAINER WHICH WAS ONLY JUST LARGER THAN THE BRASS CYLINDER.

A GERMAN CALLED HERMANN PLAUSON, PRESENTS A GREAT DEAL OF PRACTICAL INFORMATION IN HIS 1925 PATENT US1,540,998 "CONVERSION OF ATMOSPHERIC ELECTRIC ENERGY". HERMANN DESCRIBES A SYSTEM WITH 100 KILOWATTS OF OUTPUT AS A "SMALL" SYSTEM, BUT A SYSTEM OF THAT SIZE WILL ALMOST CERTAINLY HAVE MANY AERIALS PROVIDING THE INPUT. HE SAYS: "THE STATIC ELECTRICITY WHICH RUNS TO EARTH THROUGH AERIAL CONDUCTORS IN THE FORM OF DIRECT CURRENT OF VERY HIGH VOLTAGE AND LOW CURRENT STRENGTH IS CONVERTED INTO ELECTRO-DYNAMIC ENERGY IN THE FORM OF HIGH FREQUENCY VIBRATIONS".

*Fig. 1.*

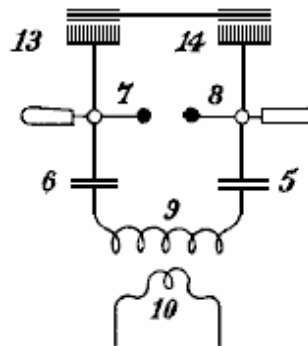

Fig.1 SHOWS A SIMPLE METHOD FOR CONVERTING STATIC ELECTRICITY INTO DYNAMIC ENERGY OF A HIGH NUMBER OF OSCILLATIONS. FOR THE SAKE OF CLARITY, A WIMSHURST MACHINE IS SHOWN AS THE INPUT RATHER THAN AN AERIAL ANTENNA.

ITEMS 13 AND 14 COLLECT THE STATIC ELECTRICITY, 7 AND 8 ARE SPARK-DISCHARGING ELECTRODES, 5 AND 6 ARE CAPACITORS AND 9 IS THE PRIMARY WINDING OF A STEP-DOWN TRANSFORMER. EACH SPARK GENERATES A LOWER VOLTAGE HIGHER CURRENT OUTPUT THROUGH 10, THE OUTPUT TRANSFORMER SECONDARY WINDING.

IN 1925 THERE WILL HAVE BEEN VERY FEW AIRCRAFT AND SO, TALL AERIALS WOULD NOT HAVE BEEN CONSIDERED A HAZARD. HERMANN CLEARLY HAD TALL AERIALS IN HIS INSTALLATIONS.

*Fig. 2.*

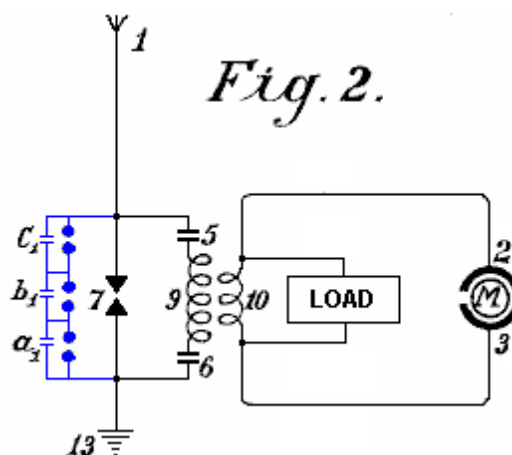
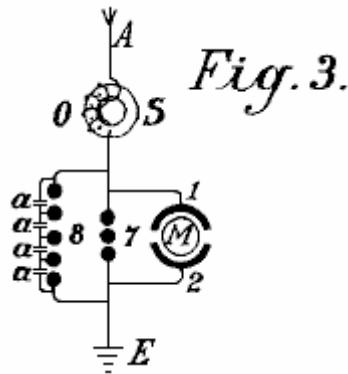

Fig.2 SHOWS AERIAL INPUT AND TWO SPARK GAPS IN PARALLEL ARE USED – THE WORKING GAP 7 AND THE MULTIPLE SPARK GAP SHOWN IN BLUE WHICH IS A SAFETY DEVICE AGAINST EXCESSIVE VOLTAGE. WITHOUT THIS SECOND SPARK GAP IT IS IMPOSSIBLE TO GATHER LARGE QUANTITIES OF ELECTRICAL ENERGY. SPECIAL MOTORS ADAPTED FOR WORKING WITH STATIC ELECTRICITY OR HIGH FREQUENCY OSCILLATIONS CAN BE CONNECTED AS AT POSITION 2 – 3.

THERE IS, OF COURSE, ALWAYS THE POSSIBILITY OF DIRECT OR NEARBY LIGHTNING STRIKES, AND SO CHOKING COILS IN THE AERIAL CONNECTION ARE USED:



THESE ARE SHOWN AS “S” IN Fig.3 AND THE CORE IS MADE WITH THE THINNEST POSSIBLE SEPARATE LAMINATIONS. IN PLACES WHERE THUNDERSTORMS ARE FREQUENT, SEVERAL SUCH CHOKE COILS MAY BE CONNECTED IN SERIES OR IN SERIES PARALLEL. IDEALLY, THE CHOKE WINDING SHOULD BE MADE UP USING SEVERAL THIN PARALLEL WIRES WHICH TOGETHER MAKE UP THE NECESSARY CROSS-SECTIONAL AREA OF WIRE.

Fig.3 SHOWS THE MOST SIMPLE WAY OF CONVERTING ATMOSPHERIC ELECTRICITY INTO ELECTROMAGNETIC WAVE ENERGY BY THE USE OF STATIC-ELECTRICITY MOTORS :

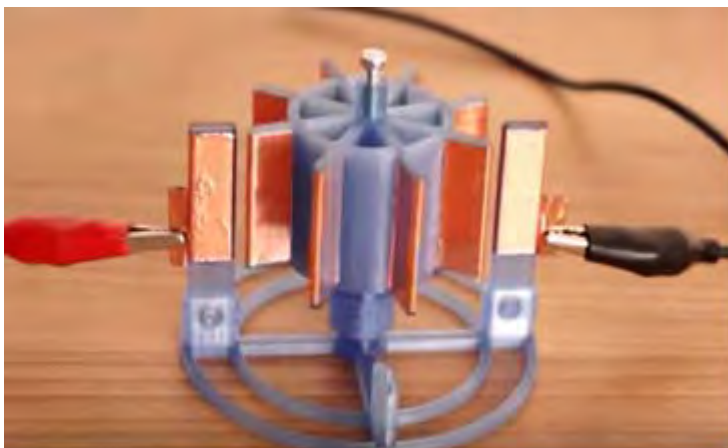

THE POSITIVE ATMOSPHERIC ELECTRIC CHARGE COLLECTED BY THE AERIAL TENDS TO COMBINE WITH THE NEGATIVE ELECTRICITY CONNECTED VIA THE EARTH WIRE. IT TRAVELS THROUGH THE AERIAL AND CHOKE “S”, FLOWING IN THE SAME DIRECTION AS THE DIRECT CURRENT. THE MOTOR “M” PROVIDES THE **CAPACITANCE, INDUCTANCE AND RESISTANCE** WHICH ARE NECESSARY FOR CONVERTING STATIC ELECTRICITY INTO ELECTROMAGNETIC WAVE ENERGY.

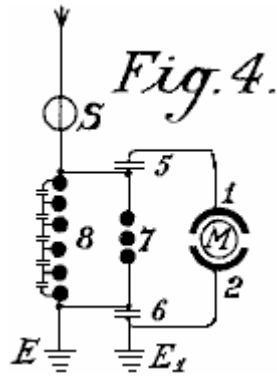

IN Fig.4, SPARK GAP 7 IS SHUNTED ACROSS CAPACITORS 5 AND 6 FROM THE MOTOR "M" AND THIS PROVIDES IMPROVED OVER-VOLTAGE PROTECTION FOR THE MOTOR AND UNIFORM EXCITATION THROUGH SPARK GAP 7.

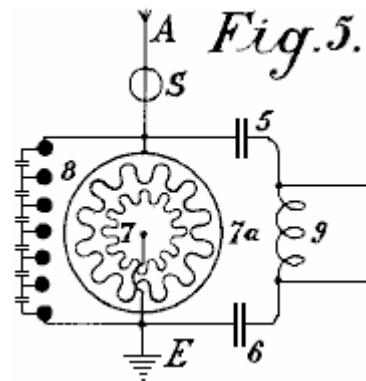

Fig.5 SHOWS AN ARRANGEMENT FOR PRODUCING LARGE CURRENTS WHICH CAN BE USED DIRECT WITHOUT MOTORS, TO PROVIDE HEATING AND LIGHTING. THE MAIN DIFFERENCE HERE IS THAT THE SPARK GAP CONSISTS OF A STAR-SHAPED DISC 7 WHICH CAN ROTATE ON ITS OWN AXIS AND WHICH IS ROTATED BY A MOTOR 7A (NOT SHOWN) INSIDE SIMILARLY SHAPED OUTER ELECTRODES. WHEN THE STAR POINTS FACE EACH OTHER, DISCHARGES TAKE PLACE, FORMING AN OSCILLATION CIRCUIT WITH THE CAPACITORS 5 AND 6. THE LOAD IS CONNECTED ACROSS INDUCTOR 9.

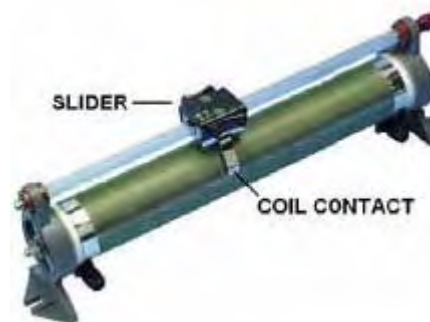
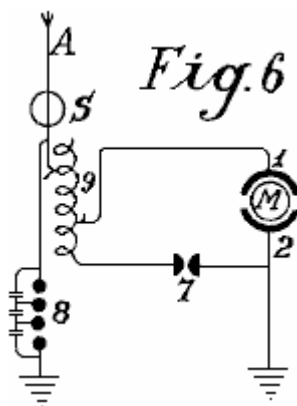

Fig.6 SHOWS HOW THE OSCILLATION CIRCUIT MAY HAVE A MOTOR CONNECTED VIA A VARIABLE INDUCTOR ("REHOSTAT") TO IT. THE MOTOR OPPOSES ANY EXCESS VOLTAGES WHICH MIGHT BE APPLIED TO THE MOTOR. BY ADJUSTING THE REHOSTAT, OPTIMUM MOTOR PERFORMANCE CAN BE ACHIEVED FOR ANY PARTICULAR AERIAL.

THERE IS SUBSTANTIALLY MORE ADVANCED INFORMATION IN THIS PATENT WHICH SEEMS TO BE MORE OF A TUTORIAL BASED ON EXTENSIVE EXPERIENCE RATHER THAN A CONVENTIONAL PATENT.

NOTES : <http://www.free-energy-info.com/FESIG3.pdf>

EBOOK : <http://www.free-energy-info.com/PJKbook.pdf>